



Advance Control Techniques for DC/DC Buck Converter with Improved Performance

Shamik Bandyopadhyay¹, Prof. G KPanda², Prof. P KSaha³, Prof. S Das⁴

PG Scholar, Dept. of EE, Jalpaiguri Government Engineering College, Jalpaiguri, West Bengal, India¹

HOD and Professor, Dept of EE, Jalpaiguri Government Engineering College, Jalpaiguri, West Bengal, India²

Professor, Dept of EE, Jalpaiguri Government Engineering College, Jalpaiguri, West Bengal, India³

Professor, Dept of EE, Jalpaiguri Government Engineering College, Jalpaiguri, West Bengal, India⁴

ABSTRACT: A buck converter is a very common and useful device in modern power electronics. It has wide application in modern HVDC power system network. The common and effective technique to control the buck converter is PID controller. PID controller is widely used in modern automatic control system. More advance technique to control the converter is non-linear control. Sliding mode control is a non-linear control technique. Every control method has some advantages and drawbacks due to which that particular control method consider as a suitable control method under specific conditions, compared to other control methods. The control method that gives the best performances under any conditions is always in demand.

KEYWORDS: PID controller, Pulse Width Modulation (PWM), Sliding mode control, DC-DC buck converter, Transfer function, MATLAB, Simulink.

I. INTRODUCTION

The switch mode DC-DC converter are some of the simplest circuit which converts power level of DC power effectively. It has wide application in modern computer, DC motor drive, power system, automotive, aircrafts etc. the commonly used control methods are pulse width modulation (PWM), voltage mode control, PWM current mode control with proportional (P), proportional integral (PI), and proportional integral derivative (PID) controller. But this control method cannot perform satisfactory under large load variation so non linear control technique is in picture. The dc-dc converters, which are non-linear and time variant system, and do not lend themselves to the application of linear control theory, can be controlled by means of sliding-mode (SM) control, Which is derived from the variable structure control system theory (VSCS).

II. LITERATURE SURVEY

The dc-dc switching converters are the widely used circuits in electronics systems. They are usually used to obtain a stabilized output voltage from a given input DC voltage which is lower (buck) from that input voltage, or higher (boost) or generic (buck-boost) [1]. Most used technique to control switching power supplies is Pulse-width Modulation (PWM) [2]. The conventional PWM controlled power electronics circuits are modelled based on averaging technique and the system being controlled operates optimally only for a specific condition [3]-[4]. The linear controllers like P, PI, and PID do not offer a good large-signal transient (i.e. large-signal operating conditions) [4]-[5].

Therefore, research has been performed for investigating non-linear controllers. The main advantages of these controllers are their ability to react immediately to a transient condition. The different types of non-linear analog controllers are: (a) hysteretic current-mode controllers, (b) hysteretic voltage-mode/V₂ controllers, (c) sliding-mode/boundary controllers. Advantages of hysteretic control approach include simplicity in design and do not require feedback loop compensation circuit. M. Castilla [6]-[8] proposed voltage-mode hysteretic controllers for synchronous buck converter used for many applications. The analysis and design of a hysteretic PWM controller with improved transient response have been proposed for buck converter in 2004[9].

International Journal of Advanced Research in Electrical, Electronics and Instrumentation Engineering

(An ISO 3297: 2007 Certified Organization)

Vol. 4, Issue 1, January 2015

III. BASIC PRINCIPLES

The buck converter circuit converts a higher dc input voltage to lower dc output voltage. The basic buck dc-dc converter topology is shown in figure. 1. It consists of a controlled switch S_w , an uncontrolled switch (diode) D , an inductor L , a capacitor C , and a load resistance R .

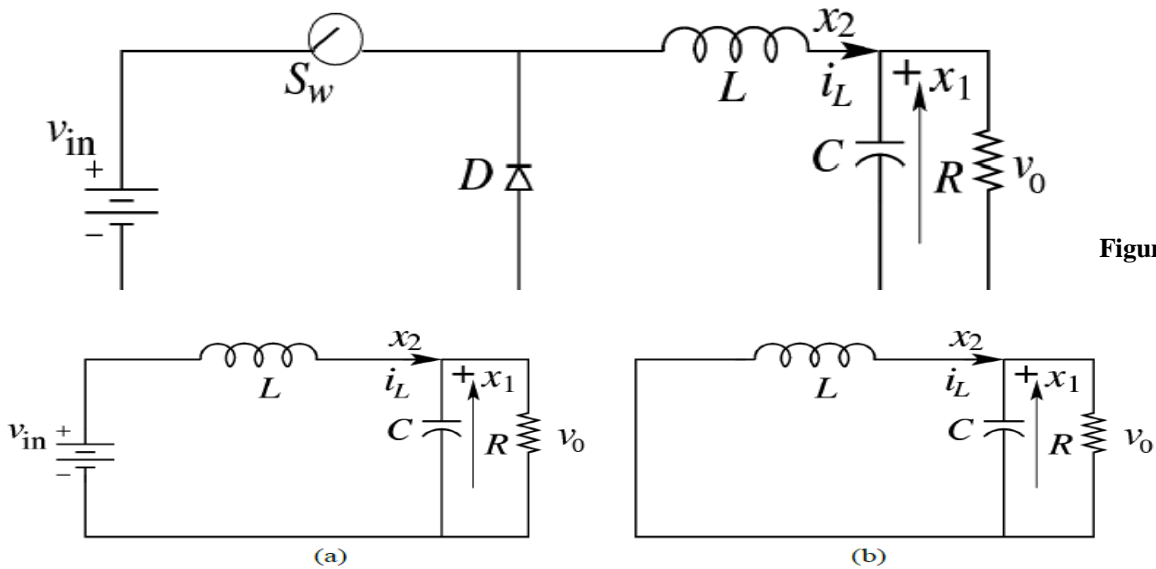

Figure 1:

Dc-Dc Buck Converter Topology

Figure 2: Buck Converter Circuit When Switch: (A) Turns On (B) Turns Off

In the description of converter operation, it is assumed that all the components are ideal and also the converter operates in CCM. In CCM operation, the inductor current flows continuously over one switching period. The switch is either on or off according to the switching function and this results in two circuit states. The first sub-circuit state is when the switch is turned on, diode is reverse biased and inductor current flows through the switch, which can be shown in figure 2(a). The second sub-circuit state is when the switch is turned off and current freewheels through the diode, which is shown figure 2(b).

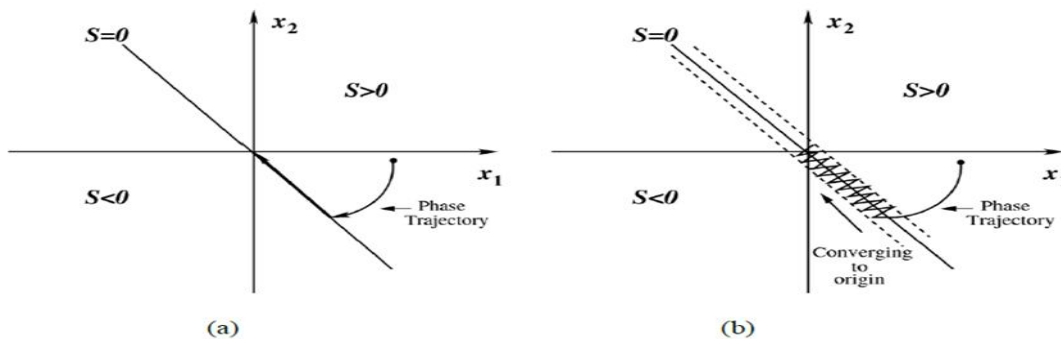

Figure 3: Phase Plot for (a) ideal SM Control (b) actual SM control

The basic idea of SM control is to design first a sliding surface in state space and then the second is to design a control law direct the system state trajectory starting from any arbitrary initial state to reach the sliding surface in finite time, and finally it should come to a point where the system equilibrium state exists that is in the origin point of the phase plane. The existence, stability and hitting condition are the three factors for the stability of sliding mode control. SM

International Journal of Advanced Research in Electrical, Electronics and Instrumentation Engineering

(An ISO 3297: 2007 Certified Organization)

Vol. 4, Issue 1, January 2015

control principle is graphically represented in Figure 3, where, represent the sliding surface and x_1 and x_2 are the voltage error variable and voltage error dynamics respectively. The sliding line (when it is a two variable SM control system in two-dimensional plane) divides the phase plane into two regions. Each region is specified with a switching state and when the trajectory arrives at the system equilibrium point, the system is considered as stable.

IV.IMPLEMENTATION OF PID CONTROLLED BUCK CONVERTER

The simulation model of DC-DC buck converter consists of following parts:

DC-DC Buck Converter: ADC-DC buck converter is a power electronics device to convert high level of voltage to a lower level voltage. In this paper the buck converter is implemented in two forms. One is mathematical modelling and another is electrical modelling. A buck converter is consists of Inductance (L), Inductance Series Resistance (RL), Capacitance (C), and Capacitance Series Resistance (Rc).

The mathematical model of the system consists of two loop. 1st one is inductor current and 2nd is output voltage loop. To design this two loop general equation must have to derive from variable system structure model.

From the general model of buck converter we can assume:

The first loop is responsible for computing the Inductor current by solving the differential equation obtained from applying KVL

$$V_{in}D = L \frac{di_L}{dt} + i_L R_L + V_0 \dots\dots 1$$

$$L \frac{di_L}{dt} = V_{in}D - i_L R_L - V_0 \dots\dots 2$$

$$i_L = \frac{i}{L} \int (V_{in}D - i_L R_L - V_0) dt \dots\dots 3$$

Where, V_{in} = Input Voltage of the Buck Converter, $D=1$ when Duty Cycle is ON and $D=0$ when Duty Cycle is OFF, i_L = Inductor Current, R_L =Effective Series Resistance of Inductance, V_0 =Output Voltage of the Buck Converter, L =Inductance Value in Henry.

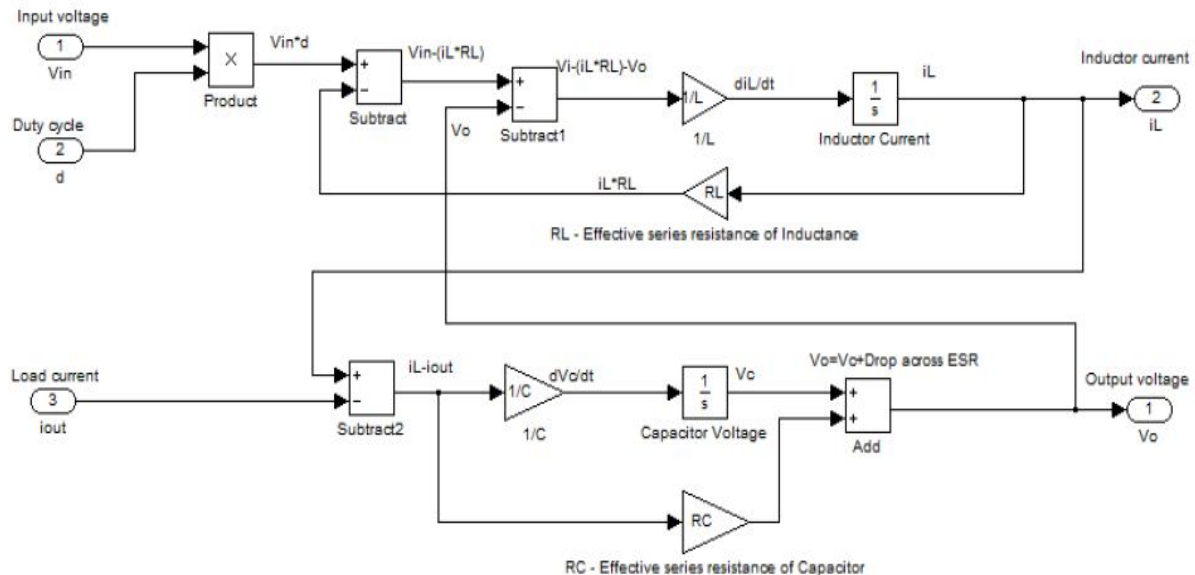

Figure 4: Buck Converter Subsystem

International Journal of Advanced Research in Electrical, Electronics and Instrumentation Engineering

(An ISO 3297: 2007 Certified Organization)

Vol. 4, Issue 1, January 2015

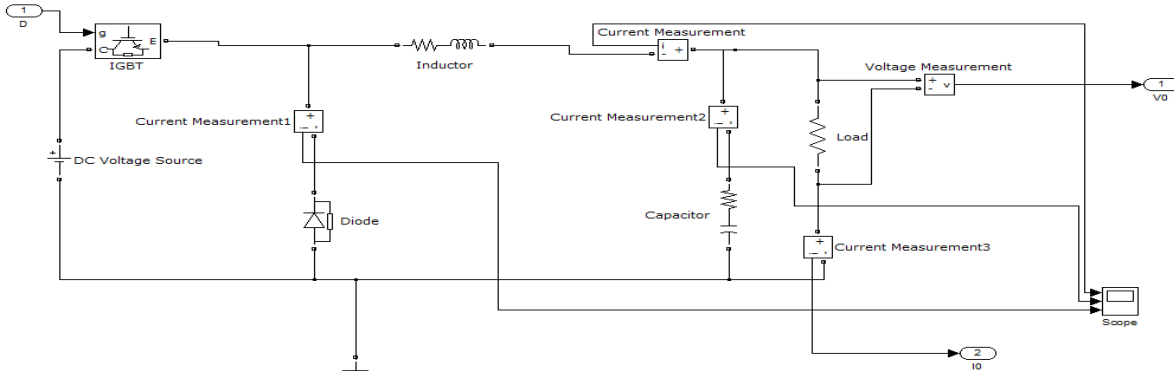

Figure 5: Buck Converter Subsystem Electrical Model

The second loop calculates the Output Voltage which is the sum of the Capacitor Voltage and the drop across the Capacitor Series Resistance (R_c). Applying KCL at the capacitor node we get:

$$C \frac{dv_c}{dt} = i_L - i_{out} \dots \dots 4$$

$$V_c = \frac{1}{C} \int (i_L - i_{out}) dt \dots \dots 5$$

$$V_0 = V_c + \text{Drop across Capacitor} \dots \dots 6$$

$$V_0 = V_c + R_c(i_L - i_{out}) \dots \dots 7$$

Where i_{out} = Load Current, C = Capacitance in Farad, V_c = Voltage across Capacitor, R_c = Effective Series resistance of the Capacitor.

PWM generator: The PWM generator produce switching frequency for the desire output by varying the duty cycle of the converter. The converter has two operating mode. The duty interval, when switch is on (T_{on}) and freewheeling mode, when switch is off (T_{off}).

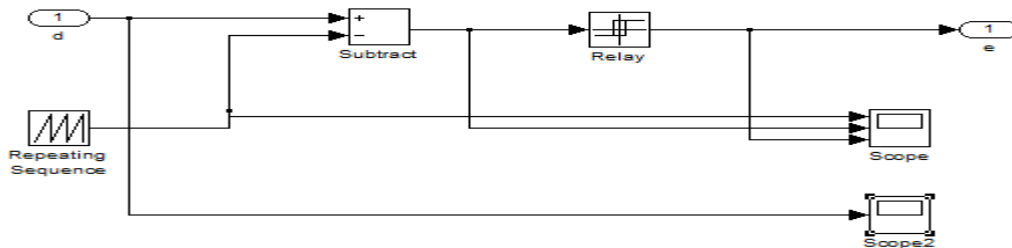

Figure 6: PWM Subsystem

To implement a PWM subsystem a relay is necessary to provide output. The input of the relay is the difference of duty cycle and saw tooth waveform. By varying the duty cycle the turn off and turn on period varies. With that the output of the relay also changes. A very simple PWM generator is designed in this paper. The time value of saw tooth is $[0 \ 0.1/fs]$, where fs is switching frequency. The only relay parameter ‘output when on’ value is 1 rest of that all value is 0.

PID Controller: To design a PID controller successfully first have to design a transfer function of the system with respect to duty cycle.

By applying Laplace Transform to Eqn (2), we get:

$$V_{in}D = Li_Ls + i_L R_L + V_0 \dots \dots 8$$

Let us assume $V_c = V_0$ by neglecting the drop across R_c . Using Laplace Transform on Eqn (9) and rearranging the terms, we get

$$i_L = \frac{V_0}{R} + CV_0s \dots \dots 9$$

By substituting the value of i_L in Equation (10) and rearranging the terms, we obtain the open loop transfer function of the Buck Converter:

International Journal of Advanced Research in Electrical, Electronics and Instrumentation Engineering

(An ISO 3297: 2007 Certified Organization)

Vol. 4, Issue 1, January 2015

$$\frac{V_o}{D} = \frac{\frac{V_{in}}{LC}}{s^2 + s\left(\frac{1}{R_o C} + \frac{R_L}{L}\right) + \left(\frac{1}{LC} + \frac{R_L}{R_o LC}\right)} \dots \dots 10$$

By applying different tuning technique like Ziegler– Nichols, Cohen–Coon the value of K_p , K_d , K_i can be derived for the system.

The proposed system is as follows:

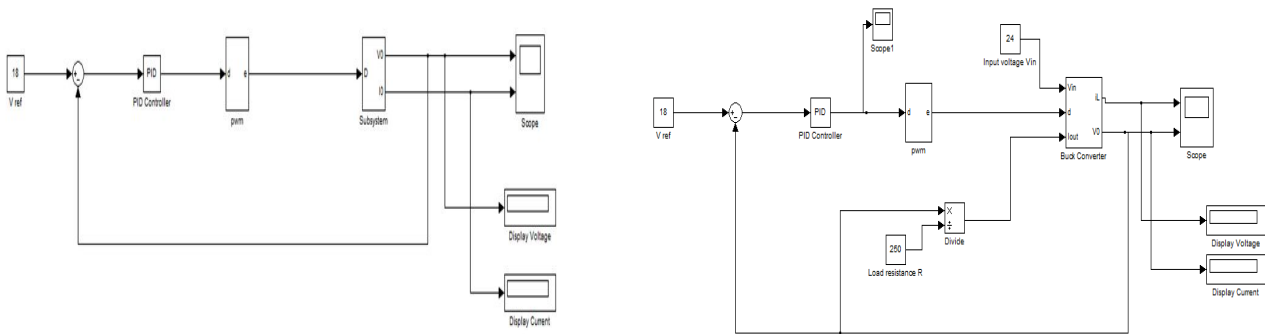

Figure 7: The Proposed Buck Converter's Electrical Model and Mathematical Model

The parameters of the model is input voltage $V_{in} = 24$ volt, reference voltage $V_{ref} = 18$ volt, inductance $L = 0.001H$, capacitance $C = 0.75\mu C$, leakage inductance $R_L = 0.08 \Omega$, leakage capacitance $R_C = 0.03$.

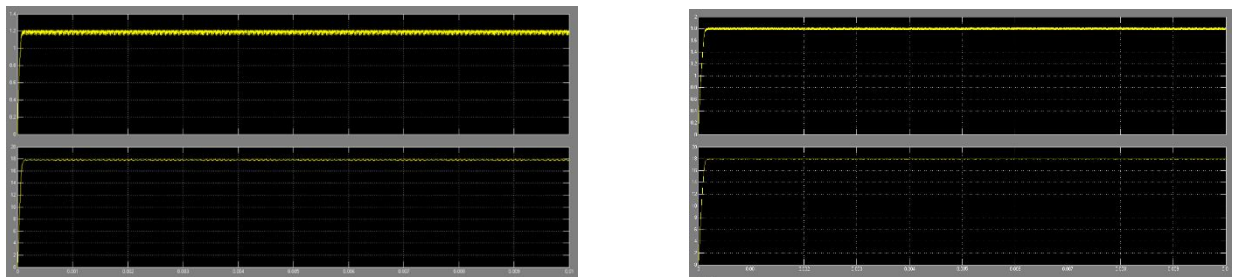

Figure 8: Output Waveform Of The Proposed Electrical&Mathematical Model 1st Output Current 2nd Output Voltage

In this model of buck converter the reference voltage V_{ref} is 18 volt constant supply. The load resistance is 10Ω . Input voltage of the converter is V_{in} is 24 volt dc supply. The output voltage of this converter is V_{out} and it is 17.66 volt and current I_{out} 1.794 amp. Both are rippled and fluctuating but magnitude is moderate.

V.SLIDING MODE CONTROL FOR BUCK CONVERTER

To design a sliding mode controller for Buck converter, the voltage error, $X1$, is

$$x1 = V_{ref} - \beta V_o \dots \dots 11$$

Where V_{ref} is the constant reference voltage and $\beta = R2 / (R1 + R2)$ is the sensing ratio of the output voltage. The rate of change of voltage error, $X2$, is

$$x2 = \dot{x1} = -\beta \frac{dV_o}{dt} = -\beta \frac{i_c}{C} \dots \dots 12$$

Where $i_c = C (dV_o/dt)$ is the capacitor current, and C is the capacitance. Since $i_c = i_L - i_R$, where i_L and i_R represent the inductor and load currents respectively, differentiation of above equation with respect to time gives

$$\dot{x2} = \frac{\beta C d(i_R - i_L)}{dt} \dots \dots 13$$

Using $i_R = V_o / R_L$ where R_L is the load resistance, and the averaged equation of a CCM inductor current

International Journal of Advanced Research in Electrical, Electronics and Instrumentation Engineering

(An ISO 3297: 2007 Certified Organization)

Vol. 4, Issue 1, January 2015

$$iL = \int \frac{uV_i - V_0}{L} Ldt \dots\dots 14$$

Where V_i is the input voltage, L is the inductance, and $u = 1$ or 0 is the switching state, we have

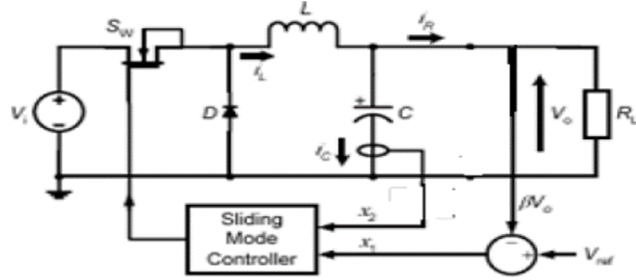

Figure 9: Schematic Diagram Of A Sliding Mode Control For Buck Converter

$$\dot{x}_2 = \frac{\beta}{R_L C} \frac{dV_0}{dt} + \frac{\beta}{C} \left(\frac{V_0 - uV_i}{L} \right) \dots\dots 15$$

$$= -\frac{x_2}{R_L C} + \frac{V_{ref}}{LC} - \frac{x_1}{LC} - u \frac{\beta V_i}{LC} \dots\dots 16$$

Finally, from (4.4) and (4.6), a state space model describing the system is derived as

$$\begin{bmatrix} \dot{x}_1 \\ \dot{x}_2 \end{bmatrix} = \begin{bmatrix} 0 & 1 \\ -1/LC & -1/R_L C \end{bmatrix} \begin{bmatrix} x_1 \\ x_2 \end{bmatrix} + \begin{bmatrix} 0 \\ -\beta V_i / LC \end{bmatrix} u + \begin{bmatrix} 0 \\ V_{ref} / LC \end{bmatrix} \dots\dots 17$$

The proposed model for buck converter is as follows:

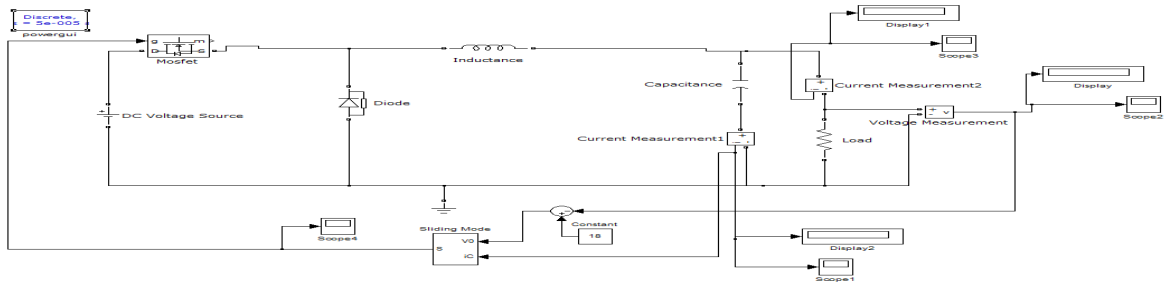

Figure 10: Simulink Model Of The Sliding Mode Control For Buck Converter

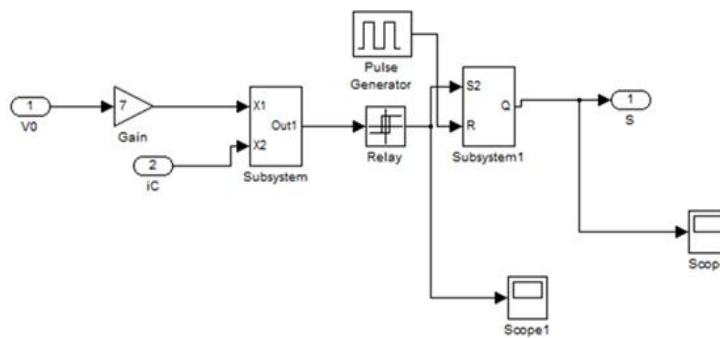

Figure 11: Sliding Surface Block Diagram

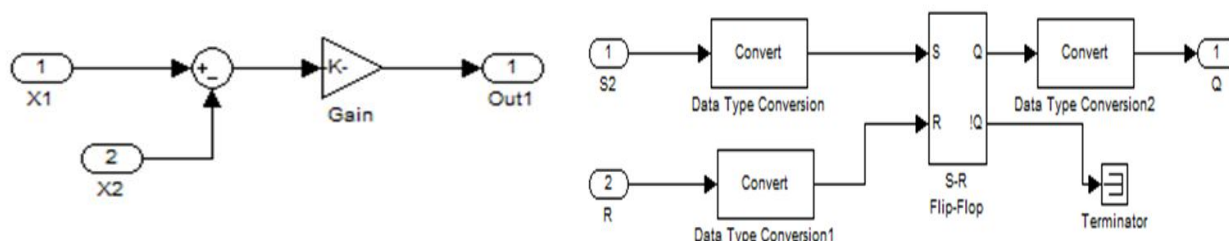

Figure 12: Sliding Line Block Diagram and SR Latch Block Diagram

VI. RESULT AND DISCUSSION

The model is verified in MATLAB/ Simulink environment. The input voltage of the buck converter is V_{in} 24 volt DC load is 10Ω . The reference signal of the system is V_{ref} 18 volt DC. The output voltage V_{out} 17.89 volt shown in fig 13 (a). The rise time of the system is 0.1 sec and no overshoot in the output voltage.

The output current waveform is in the next figure 13 (b). The value of output current is 1.764 amp. The settling time is 0.08 second.

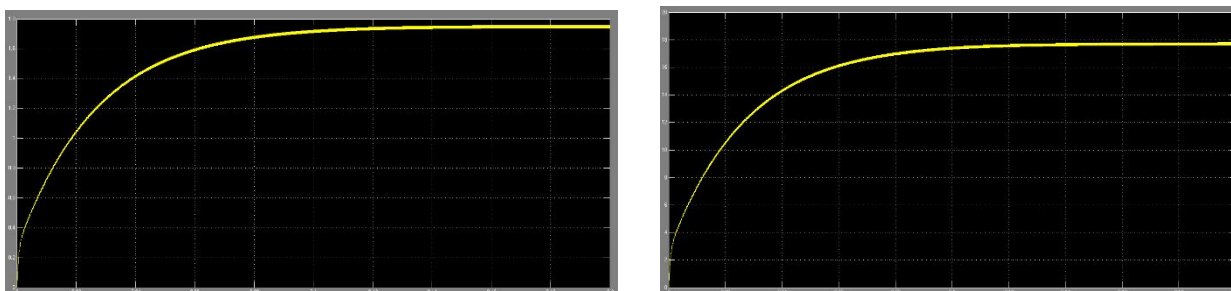

Figure 13: SM Mode Output (a) Current Waveform and (b) Voltage Waveform

The control methods have the same power circuit parameters and operate at the same input and output voltages. The design specifications and the circuit parameters, for simulation are chosen as: input voltage $V_{in} = 24V$, desired output voltage $V_{out} = 18V$, inductance $L = 100mH$, capacitance $= 150\mu F$, leakage inductance $R_L = 0.08 \Omega$, leakage capacitance $R_C = 0.03\Omega$ load resistance $R = 10\Omega$. The sliding coefficients $= 0.167$. The switching frequency is set to 150 kHz. The output is $V_{out} = 17.97$ volt $I_o = 1.764$ amp.

VII. CONCLUSION

In this section Sliding Mode control of buck converter is implemented and different output parameter is observed. The output voltage and current is stable and satisfactory. The output is better than the PID control buck converter. Output reaches stability quite fast and ripple is minimum. Load variation up to a certain range does not affect the output. The overall performance of nonlinear control is good as compared to the PID controller. PID controller reaches its final value faster but contains ripple. For different load and PID parameters there overshoot may be seen. But in SM control the output is smooth and no overshoot observed.

REFERENCES

- [1] M. H. Rashid, *Power Electronics: Circuits, Devices and Applications (3rd Edition)*, Prentice Hall, 2003.
- [2] N. Mohan, T. M. Undeland, W. P. Robbins, "Power Electronics: Converters, Applications, and Design", *3rd Bk & Cdr edition*, Wiley, 2002.
- [3] R.D Middlebrook and S Cuk , "A general unified approach to modelling switching Converter Power stages", in *Proc. IEEE PESC Rec.*, pp. 18–34, 1976.



International Journal of Advanced Research in Electrical, Electronics and Instrumentation Engineering

(An ISO 3297: 2007 Certified Organization)

Vol. 4, Issue 1, January 2015

- [4] A.J. Forsyth and S.V. Mollow, “Modelling and control of dc-dc converters”, *IEEE power engineering journal*, vol. 12, no. 5, pp. 229–236, Oct. 1998.
- [5] V.S.C Raviraj and P.C. Sen, “Comparative Study of proportional-integral, Sliding-mode, and fuzzy logic controllers for power converters”, *IEEE transaction on Industry applications*, vol. 33, no. 2, pp. 518-524, Mar./Apr. 1997.
- [6] M. Castilla, L. G. de Vicuna, J.M. Guerrero, J. Matas, and J. Miret, “Design of voltage-mode hysteretic controllers for synchronous buck converters supplying microprocessor loads”, *IEE Proceedings on Electrical Power Applications*, Vol.152, No. 5, pp.1171–1178, Sep. 2005.
- [7] M. Castilla, L. G. de Vicuna, J.M. Guerrero, J. Miret, and N. Berbel, “Simple low-cost hysteretic controller for single-phase synchronous buck converter”, *IEEE Transactions on Power Electronics*, Vol. 22, No. 4, pp.1232–1241, Jul. 2007.
- [8] M. Castilla, L. G. de Vicuna, J.M. Guerrero, J. Matas, and J. Miret, “Designing VRM hysteretic controllers for optimal transient response”, *IEEE Transactions on Industrial Electronics*, Vol. 54, No. 3, pp.1726–1738, Jun. 2007.
- [9] T. Nabeshima, T. Sato, S. Yoshida, S. Chiba, and K. Onda, “Analysis and design considerations of a buck converter with a hysteretic PWM controller”, in *Proc. IEEE PESC*, pp. 1711–1716, 2004.

BIOGRAPHY



Shamik Bandyopadhyay was born in West Bengal, India on August 16, 1990. He has received his B.Tech degree in Electrical Engineering from Dream Institute of Technology, Samali, Kolkata West Bengal in 2012. Currently he is pursuing his M.Tech degree in Power Electronics and Drives from Jalpaiguri Govt. Engineering College, Jalpaiguri, West Bengal



Prof. Gautam Kumar Panda, Professor and Head, Department of Electrical Engineering, Department of Electrical Engineering, Jalpaiguri Government Engineering College, Jalpaiguri, WB- 735102, BE (Electrical) from J.G.E. College, Jalpaiguri, M.E.E (Electrical) Specialization: Electrical Machines & drives from Jadavpur University. PhD from University of North Bengal. FIE, MISTE, Certified Energy Auditor.



Prof. Pradip Kumar Saha, Professor, Jalpaiguri Government Engineering College, Jalpaiguri, WB- 735102. BE (Electrical) from B.E. College, Shibpore. M.Tech (Electrical) Specialization: Machine Drives & Power Electronics from IIT- Kharagpur. PhD from University of North Bengal. FIE, MISTE, Certified Energy Auditor.



Prof. Sankar Das, Professor, Department of Electrical Engineering, Jalpaiguri Government Engineering College, Jalpaiguri, WB- 735102, B.Tech (Electrical) from College of Engineering & Management, Kolaghat, M.E. (Electrical) Specialization: High Voltage Engg. From Jadavpur Uni.