



International Journal of Advanced Research in Electrical, Electronics and Instrumentation Engineering

(An ISO 3297: 2007 Certified Organization)

Vol. 3, Issue 7, July 2014

An Efficient MPPT Solar Charge Controller

Dr. Anil S. Hiwale¹, Mugdha V. Patil², Hemangi Vinchurkar³

Professor and Head, Dept. of IT, MIT College of Engineering, Pune, Maharashtra, India¹

PG Student [VLSI & Embedded], Dept. of E&TC, G S Moze COE, Pune, Maharashtra, India²

PG Student [VLSI & Embedded], Dept. of E&TC, G S Moze COE, Pune, Maharashtra, India³

ABSTRACT: In this paper Maximum power point tracker battery charger is proposed for extracting maximum power from a photovoltaic panel to charge the battery. The output power of the PV system continuously varies with change in irradiance and temperature. It is very important to improve the efficiency of charger. There are number of maximum power point tracking (MPPT) methods available to operate the PV system at maximum power point. The proposed system have used Perturb & Observe (P&O) MPPT algorithm for the design and implementation. When irradiance and temperature are constant or slowly varying, the P&O method tracks MPP steadily and calculate the operating point at which the battery is capable of producing maximum power. In this method, the controller provides the PWM signal to adjust the voltage, adjustment is done by Buck converter and measures power, if the power increases, further adjustments in that direction are tried until power no longer increases.

KEYWORDS: Solar PV System, MPPT, P&O Algorithm, buck DC to DC converter, AVR Microcontroller.

I. INTRODUCTION

Solar energy is one of the most important renewable energy sources that have been gaining increased attention in recent years. Solar energy is plentiful; it has the greatest availability compared to other energy sources. The amount of energy supplied to the earth in one day by the sun is sufficient to power the total energy needs of the earth for one year. Solar energy is clean and free of emissions, since it does not produce pollutants or by-products harmful to nature. The conversion of solar energy into electrical energy has many application fields. Recently, research and development of low cost flat-panel solar panels, thin-film devices, concentrator systems, and many innovative concepts have increased. In the near future, the costs of small solar-power modular units and solar-power plants will be economically feasible for large-scale production and use of solar energy.

In this paper we have presented the photovoltaic solar panel's operation. The foremost way to increase the efficiency of a solar panel is to use a Maximum Power point Tracker (MPPT), a power electronic device that significantly increases the system efficiency. By using it the system operates at the Maximum Power Point (MPP) and produces its maximum power output. Thus, an MPPT maximizes the array efficiency, thereby reducing the overall system cost. In addition, we attempt to design the MPPT by using the algorithm of a selected MPPT method which is "Perturb and Observe" and implement it by using a DC-DC Converter. We have found various types of DC-DC converter. Among them we have selected the most suitable converter which is "BUCK" converter, for our design.

PV generation systems generally use a microcontroller based charge controller connected to a battery and the load. A charge controller is used to maintain the proper charging voltage on the batteries. As the input voltage from the solar array, the charge controller regulates the charge to the batteries preventing any overcharging. So a good, solid and reliable PV charge controller is a key component of any PV battery charging system to achieve systems maximum efficiency. Whereas microcontroller based designs are able to provide more intelligent control and thus increases the efficiency of the system.



International Journal of Advanced Research in Electrical, Electronics and Instrumentation Engineering

(An ISO 3297: 2007 Certified Organization)

Vol. 3, Issue 7, July 2014

II. LITERATURE REVIEW

There are many MPPT algorithm which can be used for implementation viz. Incremental conductance method, constant voltage method, Fuzzy logic based method etc. Different MPPT algorithms [8], [11], [12] are briefed about their features and limitations as follows

1) Incremental conductance (INC) method [8], [11] of tracking the MPP does not depend upon PV array, tracking efficiency is good, and implementation is medium. Sensing parameters are voltage and current, convergence speed is medium and of analog type.

2) Fuzzy logic control based MPPT [8], [11] is PV array dependent, Tracking efficiency is good, implementation is very complex, convergence speed is fast and of digital type.

3) Neural network based MPPT [11] is also PV array dependent, tracking efficiency is good, implementation is very complex, convergence speed is fast and of digital type.

4) Linear current control based MPPT [9], [12] is PV array dependent, tracking efficiency is not so good, implementation complexity is medium, convergence speed is fast, sensing parameter is irradiance and of digital type.

5) Temperature based MPPT [11] depends upon PV array, tracking efficiency is excellent, implementation is simple and MPP is comparatively accurate and sensing parameters are voltage and temperature.

6) Array reconfiguration based MPPT [11] is PV array dependent, tracking efficiency is poor, convergence speed is slow, implementation complexity is high, sensing parameters are voltage and current and of digital type.

7) Perturb and observe based MPPT [8], [9], [11] is not PV array dependent, tracking efficiency is good but with unstable operating points, implementation is simple, sensing parameters are voltage and current.

8) Advanced Perturb and Observe based MPPT is not PV array dependent, tracking efficiency is very good with stable MPPs, implementation is medium, sensing parameters are voltage and current.

Out of many MPPT algorithms, Perturb and observe (P&O) algorithm [10] is mostly used for increasing the efficiency of PV system due to its simpler implementation, high reliability and better efficiency.

III. SYSTEM DESCRIPTION

The objective of the paper is to present a novel cost effective and efficient microcontroller based MPPT system for solar photovoltaic system to ensure the maximum power point operation at all changing Environmental condition. The P&O MPPT algorithm is used to control the maximum transfer power from a PV panel. This algorithm is executed by an AVR Atmega16 microcontroller using the PV voltage and current data to control the duty cycle of a pulse width modulation signal applied to a DC/DC converter.

International Journal of Advanced Research in Electrical, Electronics and Instrumentation Engineering

(An ISO 3297: 2007 Certified Organization)

Vol. 3, Issue 7, July 2014

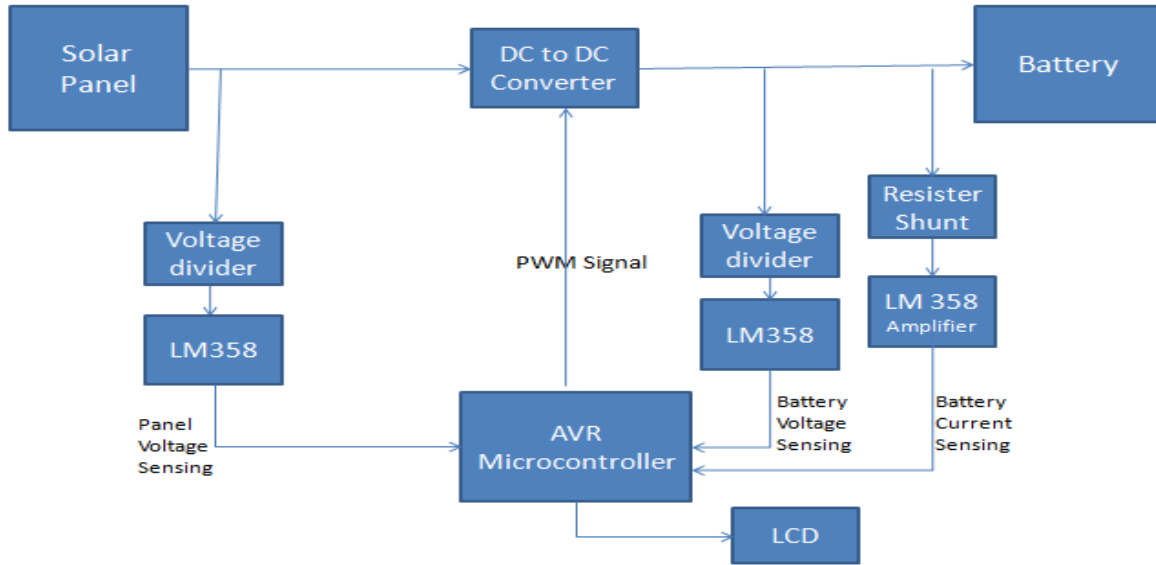

Fig. 1 System Block Diagram

A. MICROCONTROLLER

The MPPT control circuit is implemented in a microcontroller Atmega16 AVR, that has eight 10-bits analog-to-digital (A/D) converters and two four PWM mode signals. The buck converter is controlled by the microcontroller. It read the voltage and current of the solar panels through the A/D port of controller and calculates the output power. It also calculate power by reading the voltage and current of battery side in same way and send corresponding control signal to the buck converter and control the duty cycle of the converter by PWM signal through controller to accordingly increase, decrease or turn off the DC to DC converter. The ATMEGA16 is a perfect combination of performance, features, and low power consumption for this application The control circuit compares the PV output power before and after a change in the duty ratio of the DC/DC converter control signal. It is expected that the MPP presents a constant oscillation inherent to the algorithm. The following Fig no 2 is the design of AVR with LCD and oscillator Connection in proteus software.

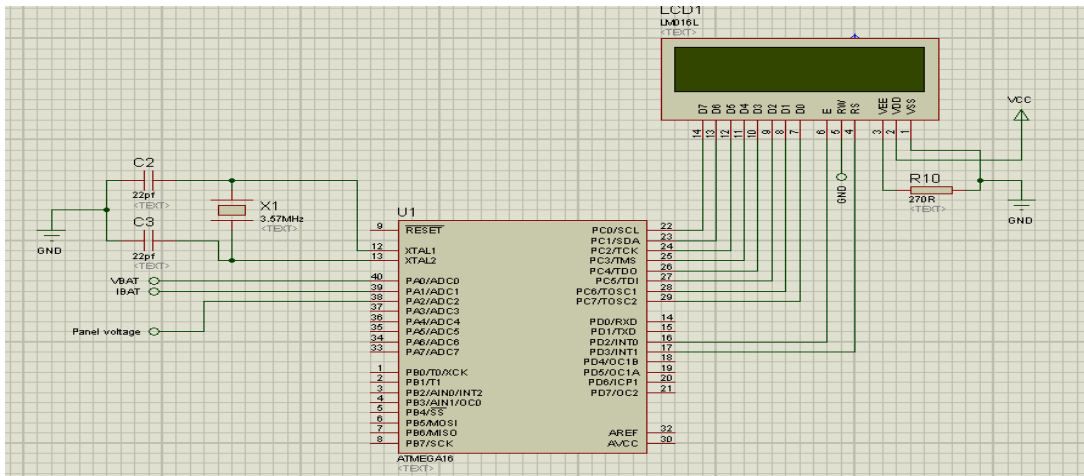

Fig. 2 AVR Microcontroller

International Journal of Advanced Research in Electrical, Electronics and Instrumentation Engineering

(An ISO 3297: 2007 Certified Organization)

Vol. 3, Issue 7, July 2014

B. DC TO DC CONVERTER

There are several topologies available for DC-DC converter. Among them buck converter is in an increasingly popular topology, particularly in battery powered applications, as level of the output voltage can be changed with respect to input voltage

The commonly used a converter in PV systems is a DC/DC power converter. It ensures, through a control action, the transfer of the maximum of electrical power to the load. The structure of the converter is determined according to the load to be supplied. In this article we focus on the step-down DC/DC converter (Buck converter). MPPT uses the same converter for a different purpose, such as regulating the input voltage at the Maximum power point and providing load matching for the maximum power transfer.

IV. P & O ALGORITHM

A typical solar panel converts only 30 to 40 percent of the incident solar irradiation into electrical energy. Maximum power point tracking technique is used to improve the efficiency of the solar panel. According to Maximum Power Transfer technique, the output power of a circuit is maximum when the source impedance matches with the load impedance. In the source side a buck converter is connected to a solar panel in order to enhance the output voltage. By changing the duty cycle of the buck converter appropriately by PWM signal the source impedance is matched with that of the load impedance. There are various MPPT techniques are proposed [3]. Among those methods, the perturb and observe (P&O) and incremental conductance (INC) methods are widely used although they have some problems such as the oscillation around MPP and confusion by rapidly changing atmospheric conditions [5]

In this paper perturb and observe MPPT algorithm is used. In this method the controller adjusts the voltage by a small amount from the array and measures power, if the power increases, further adjustments in the direction are tried until power no longer increases. This is called P&O method. Due to ease of implementation and cost effectiveness, it is the most commonly used MPPT method.

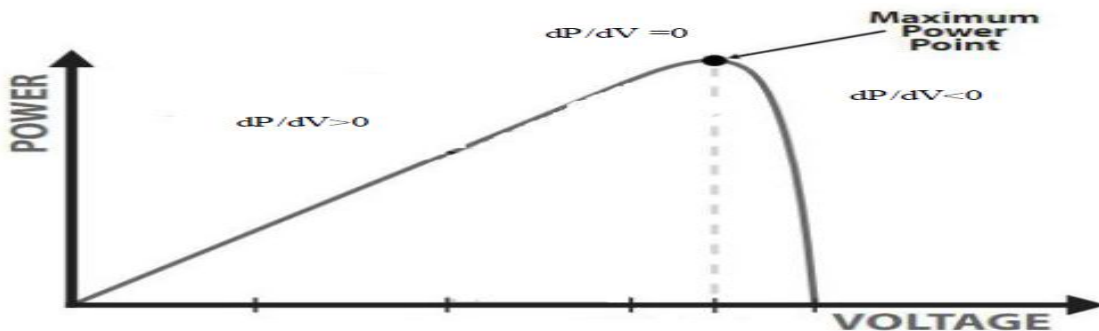

Fig. 3 Power Voltage characteristics of PV array [9]

The voltage to a cell is increased initially, if the output power increase, the voltage is continually increased until the output power starts decreasing. Once the output power starts decreasing, the voltage to the cell decreased until maximum power is reached. This process is continued until the MPPT is obtained. This result is an oscillation of the output power around the MPP. PV module's output power curve as a function of voltage (P-V curve), at the constant irradiance and the constant module temperature, assuming the PV module is operating at a point which is away from the MPP.

This P&O algorithm periodically increment or decrement the output terminal voltage of the PV cell and comparing the power obtained in the current cycle with the power of the previous one . If the power is increased, then it is supposed that it has moved the operating point closer to the MPP. Thus, further voltage perturbations in the same direction should move the operating point toward the MPP. If the power decreases, the operating point has moved away from the MPP, and the direction of perturbation should be reversed to move back toward the MPP.

International Journal of Advanced Research in Electrical, Electronics and Instrumentation Engineering

(An ISO 3297: 2007 Certified Organization)

Vol. 3, Issue 7, July 2014

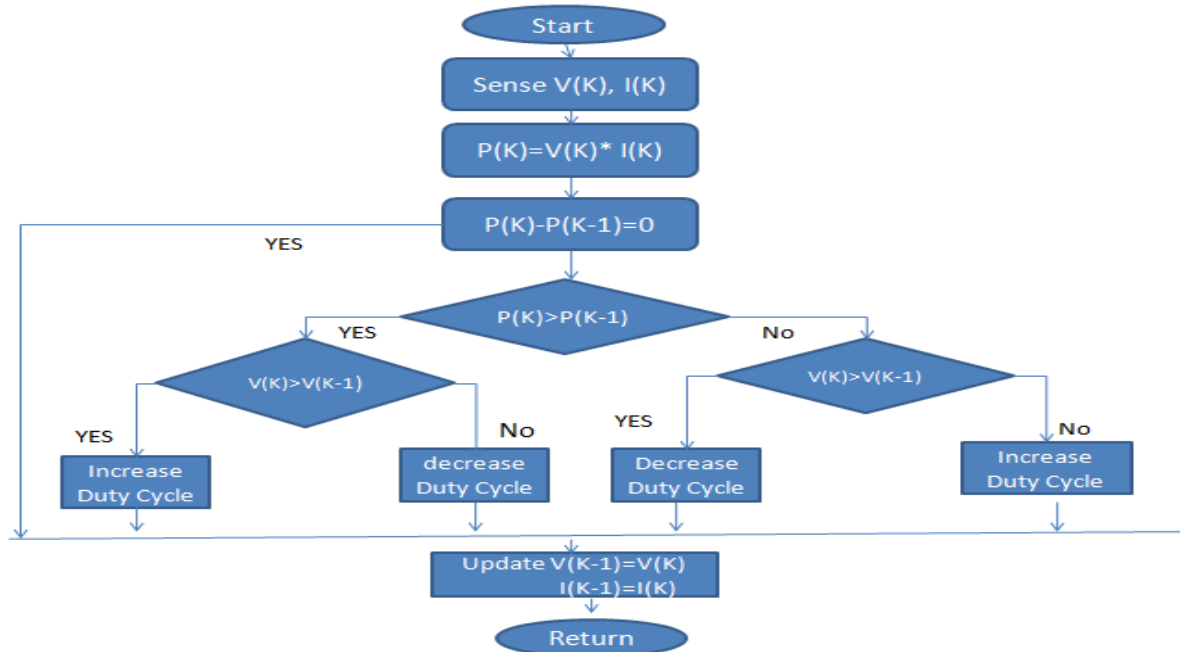

Fig. 4 Flow chart of P&O Algorithm

V. HARDWARE IMPLIMENTATION

BUCK CONVERTER

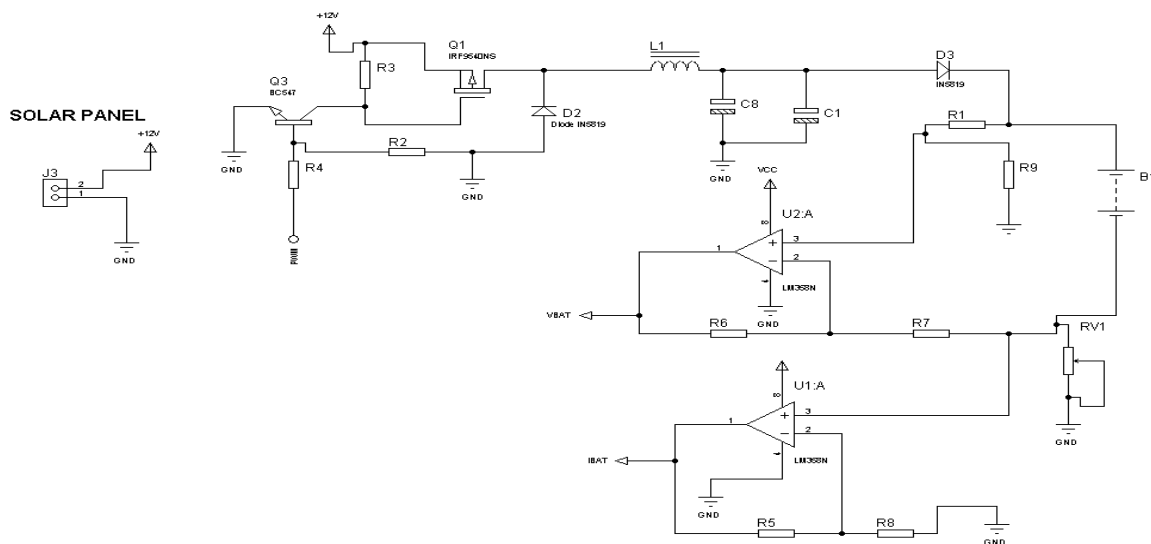

Fig. 5 Circuit Diagram of Buck Converter with Voltage and Current Sensors

International Journal of Advanced Research in Electrical, Electronics and Instrumentation Engineering

(An ISO 3297: 2007 Certified Organization)

Vol. 3, Issue 7, July 2014

The DC/DC converter is a Buck converter working at a switching frequency of 14 KHz. They consist of one P-channel MOSFET switching transistor driven by the AVR via one bipolar NPN transistor. The switching transistor is connected to an inductor, a diode and a capacitor . An additional diode prevents the battery from supplying voltage into the microcontroller when the power is disconnected. When the switching transistor is ON the capacitor is charged from the input via the inductor (the inductor is also charged up). When the switch is opened , the inductor will try to maintain its current-flow by inducing a voltage. The current flows through the diode and the inductor will charge the capacitor. Then the cycle repeats itself. If the duty cycle is decreased, by shorter on time, longer off time, the voltage will decrease. If the duty cycle is increased (longer on timer, shorter off time), the voltage will increase. The buck-converter is most efficient running on a duty cycle of 50%.

VI. RESULT

The experimental results of battery charging using the P&O MPPT algorithm are divided in two separated tests. First test, using one PV panel with $P_{max}=10\text{ W}$, $V_{mp}=17\text{ V}$, $I_{mp}=0.56\text{ A}$, under standard temperature condition and one lead-acid battery with $V = 12\text{ V}$ and $I_{max} = 7\text{ Ah}$, that consists, first, the PV panel is connected directly to the battery. From first test it can be seen that charging the 12V battery with the P&O algorithm, the absorbed power from the PV panel is around 7.35W with charging current of 0.592 A in Constant Current mode.

In the Second test, the PV panel is connected to the battery using the developed MPP tracker board running the MPPT algorithm. From first test it can be seen that charging the 12V battery with the P&O algorithm, the absorbed power from the PV panel is around 12.5W with charging current of 1.04 A. The experimental setup with the MPPT has provided always more delivered energy to the battery than the direct connection. The MPPT has increased the PV panel capacity of supply energy in 87% using a 12V battery.

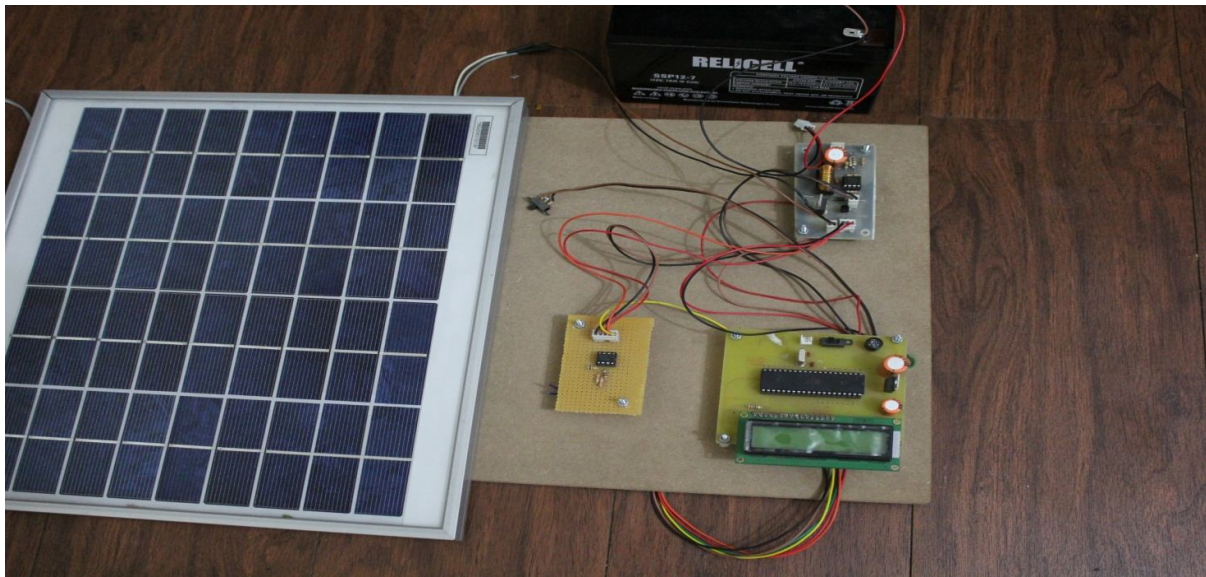



International Journal of Advanced Research in Electrical, Electronics and Instrumentation Engineering

(An ISO 3297: 2007 Certified Organization)

Vol. 3, Issue 7, July 2014

VII. CONCLUSION

This work presented a prototype board based in a small microcontroller that controls the lead acid battery charging process and also the correct used of the lead-acid battery. The control algorithm executes the P&O maximum power point tracking function allowing, according to solar irradiance, the transfer of maximum energy generated by photovoltaic panel to the battery. This P&O algorithm increase the efficiency power transference in comparison to systems that have not a MPPT (direct connection), reducing the size and the cost of the PV panel.

This board assures the fast, safe and complete battery (lead acid) charging process and also monitor its discharge. For future work the complete charging process should be analyzed to compare with another system working without P&O MPPT algorithm. From the preliminary results it is expect that the charging process using the MPPT algorithm will be faster.

REFERENCES

- [1] Sathish Kumar Kollimalla Student Member, IEEE, Mahesh Kumar Mishra Senior Member, IEEE “Novel Adaptive P&O MPPT Algorithm for Photovoltaic System Considering Sudden Changes in Weather Condition” IEEE International conference on ICCEP,2013
- [2] Moacyr Aureliano Gomes de Brito, Luigi Galotto, Jr., Leonardo Poltronieri Sampaio,Guilherme de Azevedo e Melo, and Carlos Alberto Canesin, Senior Member, IEEE “Evaluation of the Main MPPT Techniques for Photovoltaic Applications” IEEE TRANSACTIONS ON INDUSTRIAL ELECTRONICS, VOL. 60, NO. 3, MARCH 2013
- [3] D. K. Sharma , Purohit G “Advanced Perturbation and Observation (P&O) based Maximum Power Point Tracking (MPPT) of a Solar Photovoltaic System”2012 5TH International Conference on Power Electronics
- [4] Ali Chermitti, Omar Boukli-Hacene, Bencherif Mohamed “Improvement of the “Perturb and Observe” MPPT Algorithm in a Photovoltaic System under Rapidly Changing Climatic Conditions” International Journal of Computer Applications (0975 – 8887) Volume 56– No.12, October 2012
- [5] Yi-Hwa Liu,Rong-Ceng Leou ,Jeng-Shiung Cheng “Design and Implementation of a Maximum Power Point Tracking Battery Charging System for Photovoltaic Applications”power tech, 2012 russia.
- [6] Peng Fang, Pu Wang “The Research of Photovoltaic Street Light Control System with MPPT” IEEE 2011 3rd International Workshop on Intelligent Systems and Applications (ISA)
- [7] Siwakoti, Yam Prasad1, Bhupendra Bimal Chhetri, Brijesh Adhikary, Diwakar Bista “ Microcontroller based intelligent DC/DC converter to track maximum power point for solar photovoltaic module”2010 international conference on CITRES M.S.Sivagamasundari1, Dr.P.Melba Mary2,V.K.Velvizhi3 “Maximum Power Point Tracking For Photovoltaic System by Perturb and Observe Method Using Buck Boost Converter” International Journal of Advanced Research in Electrical, Electronics and Instrumentation Engineering Vol. 2, Issue 6, June 2013
- [8] D. P. Hohm and M. E. Ropp, “Comparative study of maximum power point tracking algorithms,” Prog. Photovolt: Res. Appl., vol. II, pp. 47-62,2003
- [9] Marcelo Gradella Villalva, Jonas Rafael Gazoli, Ernesto Ruppert Filho,“Analysis and simulation of the P&O MPPT algorithm using a linearized PV array model”, Industrial Electronics, 2009. IECON '09. 35th Annual Conference of IEEE.
- [10] Mohammed A. Elgendy, Bashar Zahawi, and David J. Atkinson, "Assessment of Perturb and Observe MPPT Algorithm Implementation Techniques for PV Pumping Applications" IEEE Transactions on Sustainable Energy, Vol. 3, no. 1, January 2012
- [11] Trishan Esram and Patrick L. Chapman, "Comparison of Photovoltaic Array Maximum Power Point Tracking Techniques", IEEE Transactions on Energy Conversion, vol. 22, no.2,June,2007.
- [12] Moacyr A. G. de Brito, Luigi G. Junior, Leonardo P. Sampaio, Guilherme A. e Melo, Carlos A. Canes in, "Main Maximum Power Point Tracking (MPPT) strategies intended for Photovoltaics, IEEE Transaction on Energy Conversion, Vol. 22, No. 2, June 2007