



Fetal ECG Extraction Using Adaptive Filters

Prasanth K.¹, Baby Paul², Arun A. Balakrishnan³

M. Tech scholar, Dept. of ECE, Rajagiri School of Engineering & Technology, Kochi, India¹

Associate Professor, Dept. of EC, BPC College, Piravom, India²

Assistant Professor, Dept. of AEI, Rajagiri School of Engineering & Technology, Kochi, India³

Abstract: Fetal electrocardiogram (FECG) extraction has a vital role in medical diagnosis during pregnancy. In this paper, a method for removal of background noise and artifacts from FECG signals using adaptive filters is proposed. The proposed method uses adaptive noise cancellation and digital filters for FECG extraction. Proposed FECG extraction algorithm is implemented in MATLAB using simulink models. Simulation results shows that fetal heart rate can be extracted by counting the peaks of R-R interval from the extracted FECG noise free signal.

Keywords: Electrocardiogram, Adaptive Noise Cancellation, Maternal Heart Beat, LMS algorithm

I. INTRODUCTION

Fetal heart rate (FHR) monitoring is one of the possible solution to test fetal well-being and to diagnose possible abnormalities. Fetal monitoring during pregnancy stage enables the physician to diagnose and recognize the pathologic condition especially asphyxia[1]. The electrocardiogram (ECG) is the simplest noninvasive diagnostic method for various heart diseases. Fetal ECG (FECG) signal reflects the electrical activity of the fetal heart and provides valuable information of its physiological state. Non-invasive FECG has been used to obtain valuable clinical information about the fetal condition during pregnancy by using skin electrodes placed on the maternal abdomen[2]. However, abdominal ECG (AECG) is always corrupted with power line interference, maternal ECG (MECG) and electromyogram (EMG) where as FECG signal is corrupted by the gestational age, position of the electrodes and the skin impedance.

ECG signal describes the electrical activity of the heart. An ECG signal during a cardiac cycle consists of a P wave, QRS complex and T wave. The detection of R-peaks i.e., the peaks of the QRS complex in an abdominal electrocardiogram signal provides information on the heart rate and hence it is an important tool for the physician to identify abnormalities in the heart activities. ECG signals are commonly measured at two locations: chest and abdomen[3]. The abdominal leads pick up a composite signal, consisting of the contributions from maternal electrocardiogram (MECG) and the fetal electrocardiogram (FECG) while the chest leads contains MECG only. Various research efforts have been proposed to extract the FECG from the AECG such as adaptive filtering, correlation techniques, blind source separation and a combination of wavelet analysis and blind source separation methods. FHR can be calculated by determining the R-R intervals from the extracted FECG[4]. However, the extracted FECG is still corrupted by the residual peaks of MECG (especially its QRS complexes) hence the FECG detection remains difficult.

Rest of the paper is organized as follows. Section II deals with data acquisition and the proposed algorithm for fetal heart rate extraction is discussed in section III. Simulation results of the proposed method is discussed in Section IV and finally section V concludes the paper.

II. DATA ACQUISITION

The shapes of the electrocardiogram signals for both the mother and fetus is simulated assuming that a mother's heart might produce a 4000 Hz sampling rate. The heart rate for this signal is approximately 89 beats per minute, and the peak voltage of the signal is 3.5 millivolts. The heart of a fetus beats noticeably faster than that of its mother, with rates ranging from 20 to 160 beats per minute[5]. The amplitude of the fetal electrocardiogram is also much weaker than that of the maternal electrocardiogram. The heart rate for the fetal electrocardiogram signal corresponds to 139 beats per minute and a peak voltage of 0.25 millivolts.

The measured fetal electrocardiogram signal from the abdomen of the mother is usually dominated by the maternal heartbeat signal that propagates from the chest cavity to the abdomen. This propagation path can be described as a linear FIR filter with 10 randomized coefficients. In addition, a small amount of uncorrelated Gaussian noise is added to simulate any broadband noise sources within the measurement. The maternal electrocardiogram signal is obtained from the chest of the mother. The goal of the adaptive noise canceller in this task is to adaptively remove the maternal heartbeat signal from the fetal electrocardiogram signal. The noise canceller needs a reference signal generated from the maternal electrocardiogram to perform this task. Just like the fetal electrocardiogram signal, the maternal electrocardiogram signal will contain some additive broadband noise.



III. PROPOSED ALGORITHM

The block diagram of the proposed algorithm is shown in Fig. 1.

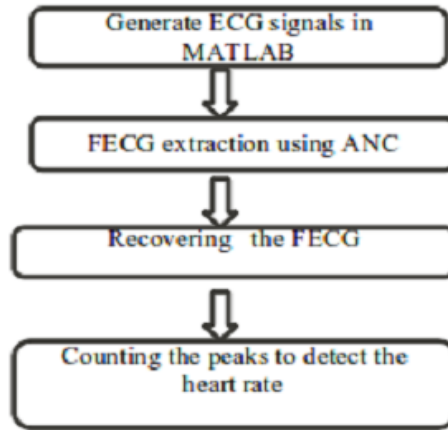

Fig. 1 Algorithm for FECG Extraction

A. Generation of ECG signals in MATLAB

MATLAB is used for simulating shapes of the electrocardiogram for both the mother and fetus. Fig. 2 shows the Maternal ECG signal generated for mothers heart assuming a 4000 Hz sampling rate[6]. The heart rate for this signal is approximately 89 beats per minute, and the peak voltage of the signal is 3.5 millivolts. The heart of a fetus beats noticeably faster than that of its mother, with rates ranging from 120 to 160 beats per minute. Fig. 3 shows the FECG signal generated. The measured fetal electrocardiogram signal from the abdomen of the mother is shown in Fig. 4. It is usually dominated by the maternal heartbeat signal that propagates from the chest cavity to the abdomen.

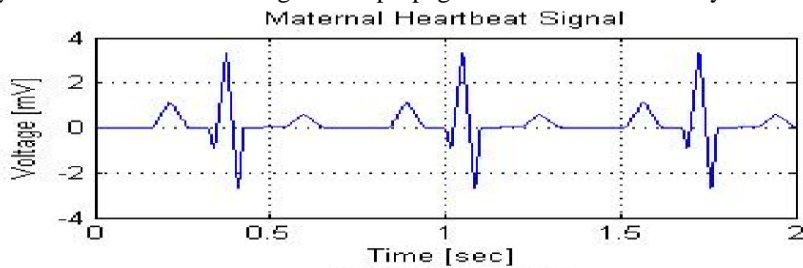

Fig. 2 Maternal heartbeat signal



Fig. 3 Fetal electrocardiogram signal

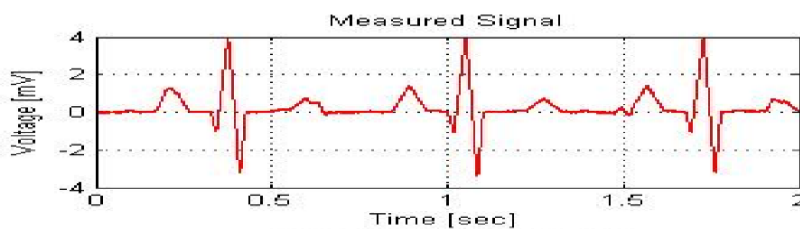

Fig. 4 Measured FECG signal from abdomen of mother



B. FECG Extraction Methods

1) *Adaptive noise canceller:* Removal of background noise and artifacts from FECG signals using adaptive filters necessitates the application of two input signals; The primary signal is FECG signal added with MECG signal and the secondary signal is the reference signal which is the noise to be canceled i.e., MECG signal. The secondary noise signal must be well-correlated with the noise in the primary signal. Adaptive filters are used in fetal electrocardiography, in which a maternal heartbeat signal is adaptively removed from a fetal heartbeat signal.

An adaptive filter operating in a stationary environment, the error-performance surface has a constant shape as well as orientation[7]-[10]. When the adaptive filter operates in a non-stationary environment, the bottom of the error-performance surface continually moves while the orientation and curvature of the surface may be changing too. Therefore, when the inputs are non-stationary, the adaptive filter has the task of not only seeking the bottom of the error performance surface, but also continually tracking it. Fig. 5 shows a basic adaptive noise cancellation system.

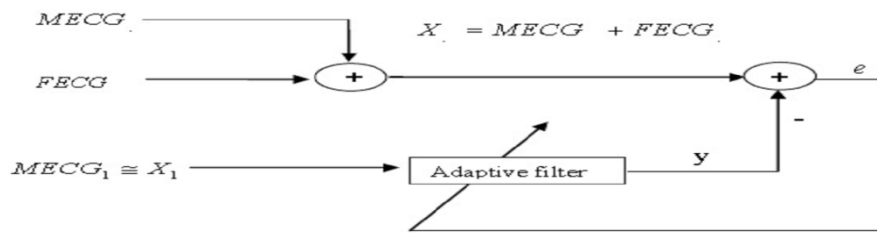

Fig. 5 Adaptive noise canceller

If it is possible to make exact measurements of the gradient vector at each iteration, and if the step-size parameter is suitably chosen, then the tap-weight vector computed by using the method of steepest-descent would indeed converge to the optimum Wiener solution[9]. The tap-weight vector is updated in accordance with an algorithm that adapts to the incoming data. One recursive algorithm for changing tap-weight vector is Least Mean Square (LMS) algorithm as in (1). Advantage of LMS algorithm is simplicity because it does not require any matrix inversion.

$$W_{k+1} = W_k + 2 \mu \epsilon_k X_k(1)$$

where W_k is the tap-weight vector at k^{th} iteration, μ is the step size parameter, ϵ_k is the error at k^{th} iteration and X_k is the input signal vector.

2) *Digital filter for high frequency removal:* FIR filters are one of two primary types of digital filters used in Digital Signal Processing (DSP) applications, the other type being IIR. FIR filters can easily be designed to be "linear phase" without any phase distortion. They are suited to multirate applications like "decimation" (reducing the sampling rate) or "interpolation" (increasing the sampling rate), or both. Whether decimating or interpolating, the use of FIR filters allows some of the calculations to be omitted, thus providing an important computational efficiency. In order to fetal heart rate are the peaks corresponding R wave of the FECG need to be extracted. To achieve this in first stage an FIR filter is used with appropriate filter coefficients to remove high frequency. The peak corresponding to the R wave of the FECG are extracted by fixing the threshold value slightly around than the normal level. From the R-R interval the FETAL heart rate can be obtained.

IV. RESULTS AND DISCUSSION

A. Simulink Model

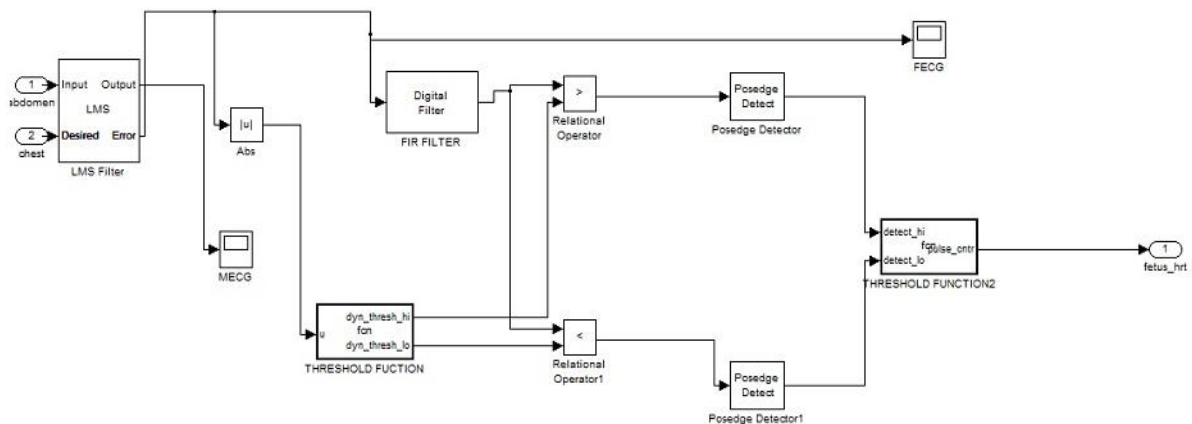

Fig. 6 Proposed simulink model for FECG extraction



Simulink model is implemented to identify the heart rate of a fetus based on sensor data from two electrodes. There are two primary signals (mother and baby's heartbeat) with noise superimposed. Fig. 6 shows the proposed simulink model for FECG extraction. The goal is to filter out everything but the baby's heartbeat and calculate the period of the signal based on our estimation of that heartbeat.

B. Adaptive noise canceller extraction technique

The adaptive noise canceller can use almost any adaptive procedure to perform its task. for simplicity, we shall use the least-mean-square (lms) adaptive filter with 15 coefficients and a step size of 0.00007. With these settings, the adaptive noise canceller converges reasonably well after a few seconds of adaptation, certainly a reasonable period to wait under this particular diagnostic application[7]. Fig. 7 shows the measured FECG and Fig. 8. shows the adaptive noise canceller output.

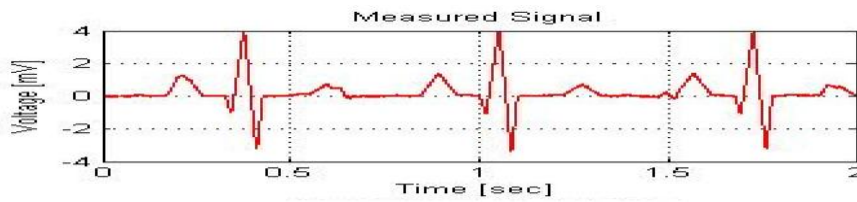

Fig. 7 The measured fetal electrocardiogram

C. Counting the peaks to detect the heart rate

The idea is to clean up the signal, and then set some dynamic threshold, so that any signal crossing the threshold is considered a peak[1]. The peaks can be counted per time window. Fig. 9 shows the peaks that can be counted per time window and Fig. 10 shows the graph of FECG heart rate.

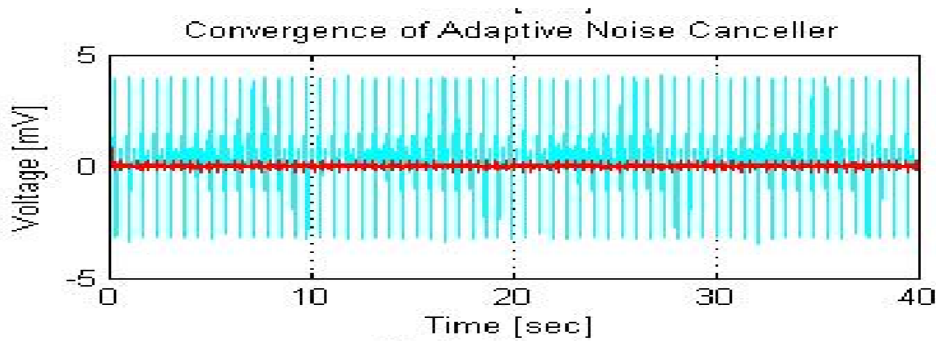

Fig. 8 Adaptive noise canceller output

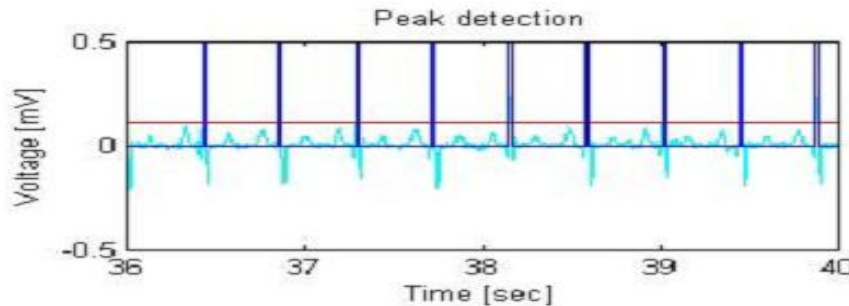

Fig. 9 Peak detection

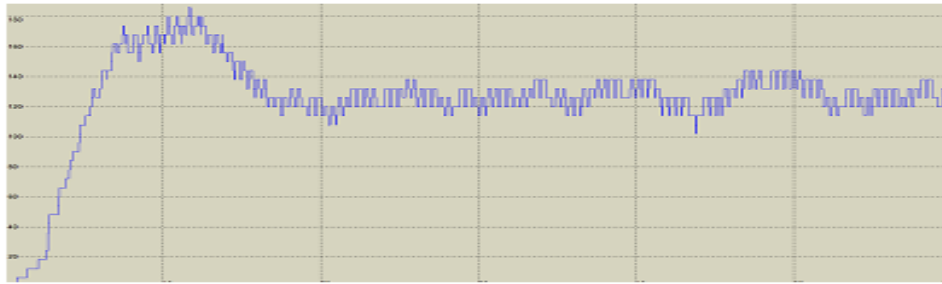

Fig. 10 FECG Heart rate

V. CONCLUSION

An adaptive noise canceller based fetal electrocardiogram extraction method is proposed and implemented. From the simulation results we can conclude that FECG signals can be extracted from the abdominal electrocardiogram signals using LMS algorithm for changing tap-weight vector. Software implementation of LMS algorithm is presented to implement the ANC system and the proposed algorithm is implemented using simulink. Fetal heart rate signals are extracted from the peaks of R-R interval.

REFERENCES

- [1] Freeman, R. K., Garite, T. J., Nageotte, M. P., and Miller, L. A., "Fetal heart rate monitoring", LWW, 2012.
- [2] Kumar, A., Dewan, L., Singh, M., and Kurukshetra, H., "Realtime monitoring system for ECG signal using virtual instrumentation", IEEE Transactions on Biology and Biomedicine, vol. 3, pp. 638–643, 2006.
- [3] Ferrara, E. R., and Widrow, B., "Fetal electrocardiogram enhancement by time-sequenced adaptive filtering", IEEE Trans. Biomed. Eng. 29, pp. 458–460, 1982.
- [4] Peters, M., Crowe, J., Pieri, J. F., Quartero H., Hayes-Gill, B., James, D., Stinstra, J., and Shakespeare, S., "Monitoring the fetal heart non-invasively: a review of methods", Journal of perinatal medicine, vol. 29, no. 5, pp. 408–416, 2001.
- [5] Ananthanag, K., and Sahambi, L., "Investigation of blind source separation methods for extraction of fetal ECG", In Canadian Conference on Electrical and Computer Engineering. May 2003.
- [6] Jafari, M. G., and Chambers, J. A., "Fetal electrocardiogram extraction by sequential source separation in the wavelet domain", IEEE Transactions on Biomedical Engineering, vol. 52, no. 3, pp.390–400, 2005.
- [7] Haykin, S., "Adaptive Filter Theory", 3rd Edition, Prentice Hall 2002 .
- [8] Widrow, B., "Adaptive Noise Cancelling: Principles and Applications", Proc. IEEE, vol. 63, pp.1692-1716, Dec. 1975.
- [9] John, R. G. Jr., "Adaptive Noise Canceling Applied to Sinusoidal Interferences", IEEE Trans. ASSP, Vol. ASSP-25, no. 6, pp. 484-491, Dec.1977
- [10] Shik Ryu, B., and Lee, J. K., "The Performance of an adaptive noise canceller with DSP processor", 40th Southeastern Symposium on System Theory, New Orleans, USA, March 16-18, pp 42-45, 2008.