

# High Efficiency Boost Rectifier (Bridgeless) For Energy Harvesting

Md. Jahid Hasan<sup>1</sup>, Md. Hasibul Islam<sup>2</sup>, Qazi Tareq<sup>3</sup>

Undergraduate student, Dept. of EEE, AIUB, Dhaka, Bangladesh<sup>1</sup>

Undergraduate student, Dept. of EEE, AIUB, Dhaka, Bangladesh<sup>2</sup>

Undergraduate student, Dept. of EEE, AIUB, Dhaka, Bangladesh<sup>3</sup>

**ABSTRACT:** The conventional ac-dc converters for energy harvesting system with diode rectifiers suffers considerable voltage drop results increase in power loss of circuitry and complexity. The bridgeless boost rectifier which is a unique integration of boost and buck boost to condition the positive and negative half portions of the input ac voltage, respectively. Such a single stage ac-dc converter has been designed and simulated using MATLAB/SIMULINK at 50-kHz switching frequency. The boost and buck-boost topologies could share same inductor and capacitor to meet the miniature size and weight requirements. The input ac voltage with 10V amplitude is rectified and stepped up to 30V dc. Detailed design guidelines are provided with the purpose of minimizing the size, weight, and power losses.

**KEYWORDS:** Ac/dc conversion, boost, bridgeless, buck-boost, energy harvesting.

## I.INTRODUCTION

In energy harvesting systems, power electronic circuit forms the key interface between transducer and electronic load, which might include a battery. A compact, highly efficient power management circuit is as important as the harvester itself. A complete energy harvesting solution obviously requires the harvester for mechanical to electrical energy conversion, but also application specific power management circuitry to perform ac/dc rectification, voltage/current boost, voltage/current regulation, and other power management functions. Conventional ac-dc converters for energy harvesting and conditioning usually consists of two stages. A diode bridge rectifier typically forms the first stage, while the second stage is a dc-dc converter to regulate the rectified ac voltage to a dc voltage (in Fig. 1). This arrangement of two stage power conversion has several disadvantages:

- 1) Diode voltages in a bridge rectifier are difficult to overcome for low input voltage.
- 2) Diode losses are increased, as input current is much higher than output current.
- 3) A rectifier offers a nonlinear load, which makes the converter unsuitable for energy harvesting.

To overcome these drawbacks, CMOS diodes with low voltage drops are investigated in the bridge rectifiers, to substitute conventional p-n junction diodes. Such diodes include 1) diode-connected passive MOSFET, which adopts threshold voltage cancellation techniques and 2) MOSFET, which is actively controlled by a comparator.

In the either case, the low-voltage-drop diode techniques require either additional bias networks or external comparators. Thus, both the complexity and the power loss of the circuitry would increase.

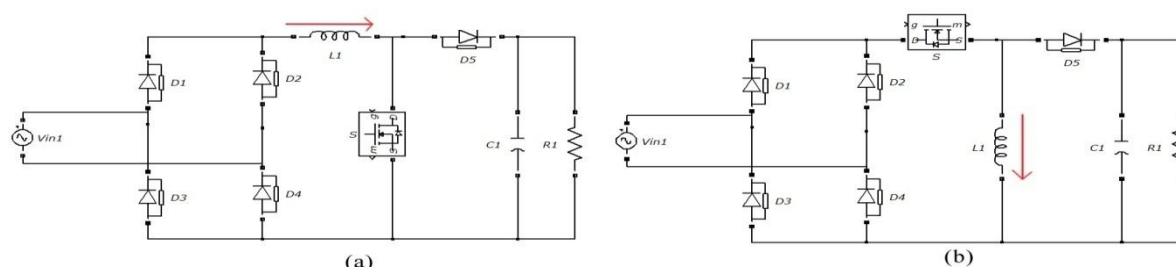

**Figure 1:** Conventional two-stage diode-bridge ac-dc converters.

(a) Boost rectifier. (b) Buck-boost rectifier

Another approach to maximize the conversion efficiency in low-voltage rectification is to use bridgeless direct ac–dc converters. Those topologies either use bidirectional switches and split capacitors, or two parallel dc–dc converters to condition positive and negative input voltages separately. For the split-capacitor topologies [in Fig. 2(a)–(c)], due to the low operation frequency, the capacitors have to be large enough to suppress the voltage ripple under a desired level. The increased size and number of energy storage components make those topologies impractical due to the size limitation of energy harvesters. On the other hand, the split capacitors could be eliminated by using two synchronous MOSFETs [in Fig. 2(d)]. However, the additional switches would incur extra switch loss and driving circuit dissipations.

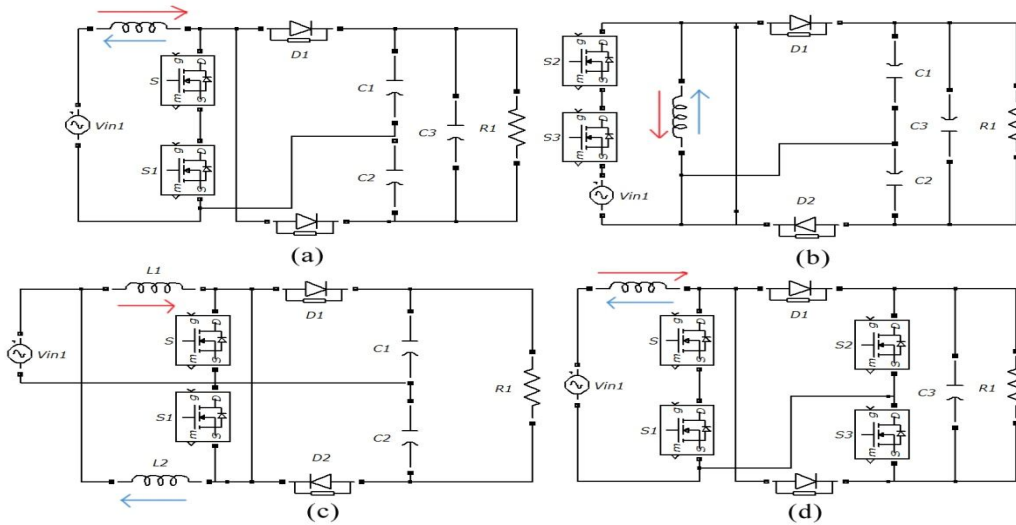

**Figure 2:** Bridgeless ac–dc converters [6]. (a) Split capacitor boost converter.(b) Split capacitor buck-boost converter. (c)Dual polarity boost converter.(d) Boost converter with secondary switches.

Step up the input voltage with a reverse polarity; hence, it is an appropriate candidate to condition the negative voltage cycle. Beside the boost and buck – boost topologies, it could share the same inductor and capacitor to meet the miniature size and weight requirements. A new bridgeless boost rectifier, shown in Fig. 3, which is a unique integration of boost and buck-boost converters, is presented in this paper. When the input voltage is positive,  $S1$  is turned ON and  $D1$  is reverse biased, the circuitry operates in the boost mode. As soon as the input voltage becomes negative, the buck boost mode starts with turning ON  $S2$  and reverse biasing  $D2$ . MOSFETs with bidirectional conduction capability work as two-quadrant switches to ensure the circuitry functionality in both positive and negative voltage cycles. This topology was introduced in [10] for piezoelectric energy harvesting applications.

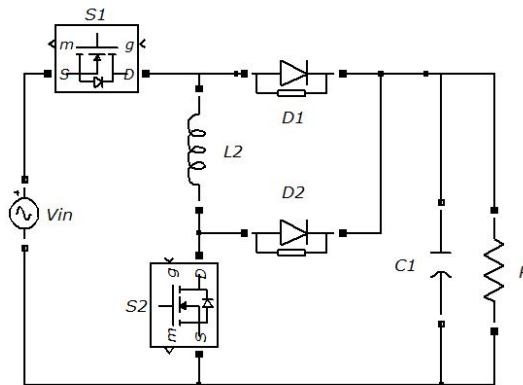

**Figure 3:** Bridgeless boost rectifier for energy harvesting

The circuit operation modes are described in Section 2. In Section 3, the design procedures and guidelines are discussed. Section 4 addresses the simulation results. Section 5 presents the conclusions.

## II. PRINCIPLE OF OPERATION

The power electronics interface (PEI) is employed to supply constant voltage and to deliver power to the load. In order to facilitate and simplify analyses, it is assumed that the input impedance of the PEI is significantly larger than the internal impedance of energy harvesting device. The induced voltage could be assumed to be a low amplitude sinusoidal ac voltage source. In this paper, a 10-V, 50-Hz sinusoidal ac voltage source is adopted to emulate the output of the energy harvester.

The DCM operating modes of the proposed boost rectifier are shown in Fig. 4. Each cycle of the input ac voltage can be divided into six operation modes. Modes I–III illustrate the circuit operation during positive input cycle, where  $S_1$  is turned ON while  $D_1$  is reverse biased. The converter operates as a boost circuit during Modes I–III, while switching  $S_2$  and  $D_2$ . The operation during negative input cycle is demonstrated in Modes IV–VI, where  $S_2$  is turned ON while  $D_2$  is reverse biased. In these modes, the converter operates similar to a buck-boost circuit.

**Mode I:** This mode begins when  $S_2$  is turned ON at  $t_0$ . The inductor current is zero at  $t_0$ . The turn on of  $S_2$  is achieved through zero current switching (ZCS) to reduce switching loss. Inductor  $L$  is energized by the input voltage as both  $S_1$  and  $S_2$  are conducting. Both diodes are reverse biased. The load is powered by the energy stored in the output filter capacitor  $C$ .

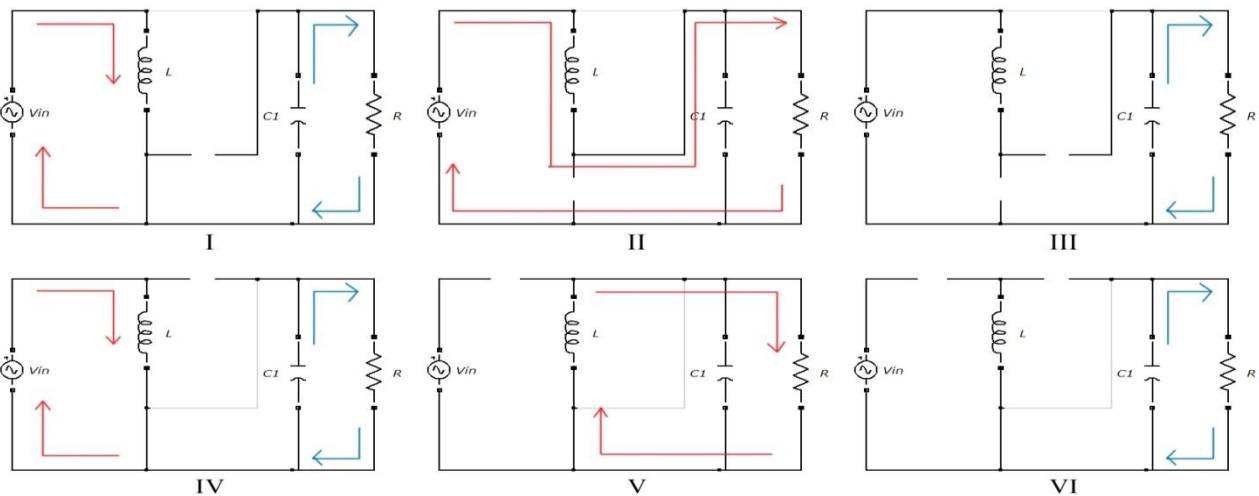

**Figure 4:** Operating modes of the proposed boost rectifier

**Mode II:**  $S_2$  is turned OFF at  $t_1$ , where  $t_1 - t_0 = d_1 T_s$ ,  $d_1$  is the duty cycle of the boost operation, and  $T_s$  is the switching period. The energy stored in the inductor during Mode I is transferred to the load. The inductor current decreases linearly. During this mode, switching loss occurs during the turn on of diode  $D_2$ .

**Mode III:**  $D_2$  is automatically turned OFF as soon as the inductor current becomes zero at  $t_2$  ( $t_2 - t_1 = d_2 T_s$ ). This avoids the reverse recovery loss of diode. The load is again powered by the stored energy in the capacitor. The converter would return to Mode I as soon as  $S_2$  is turned ON, if the input voltage is still in positive cycle.

**Mode IV:** During the negative input cycle, Mode IV starts as soon as  $S_1$  is turned ON at  $t_{-0}$ . ZCS condition can also be achieved by ensuring the converter operation in DCM. The energy is transferred to the inductor  $L$  again, while the output filter capacitor  $C$  feeds the load.

**Mode V:** At  $t_{-1}$ ,  $S_1$  is turned OFF, where  $t_{-1} - t_{-0} = d_{-1} T_s$ ,  $d_{-1}$  is the duty cycle of the buck-boost operation. The energy stored in the inductor during Mode IV is transferred to the load. The inductor current decreases linearly. During this mode, switching loss occurs during the turn on of the diode  $D_1$ .

# International Journal of Advanced Research in Electrical, Electronics and Instrumentation Engineering

(An ISO 3297: 2007 Certified Organization)

Vol. 3, Issue 10, October 2014

**Mode VI:** When the inductor current decreases to zero at  $t_{22}$  ( $t_{22} - t_{21} = d_2 T_s$ ),  $D1$  is turned OFF at zero current. The load is continuously powered by the charge stored in the output capacitor. The converter would return to Mode IV as soon as  $S1$  is turned ON, if the input voltage is still negative.

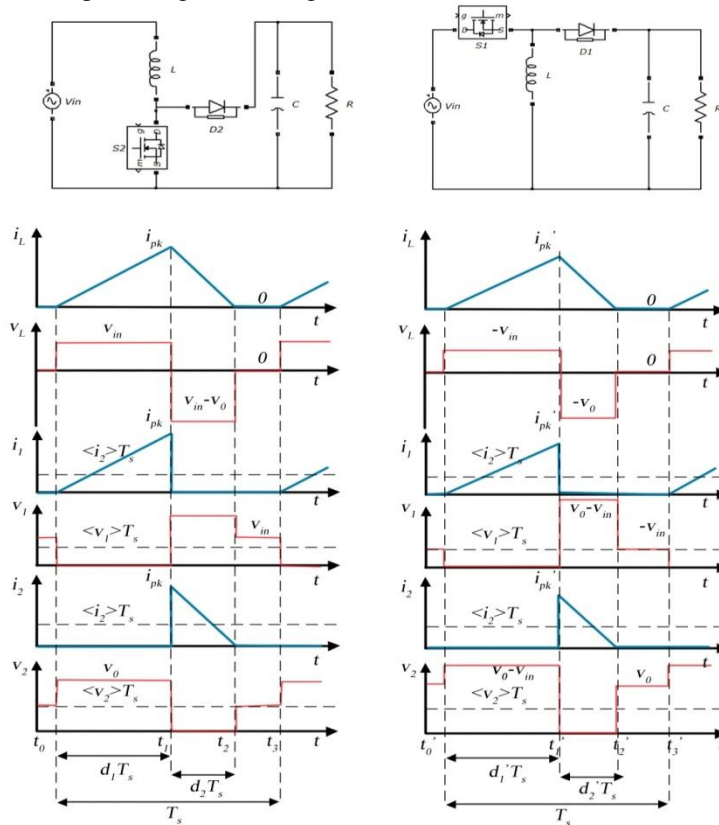

**Figure 5:** Waveforms of the proposed boost/buck-boost rectifier. (a) Boost operation. (b) Buck-boost operation

According to the analyses of operation modes, the switches are turned ON with ZCS and the diodes are turned OFF with ZCS. Due to the DCM operation, the input current sensor can be eliminated and switching loss can be reduced. Moreover, the control scheme of DCM operation is relatively simpler. Since the circuit size can be reduced and the efficiency can be enhanced, DCM operation is more suitable than continuous conduction mode (CCM) operation.

### III. DESIGN PROCEDURE

In order to design the circuit, several assumptions are made during one switching cycle. The output filter capacitor  $C$  is large enough to keep the output voltage  $V_0$  constant. The input is a sinusoidal voltage source. The switching frequency is much higher than the input voltage frequency. During each switching cycle, the input voltage could be treated as a constant voltage source and be expressed as (1), where  $V_{in}$  is the period of input voltage

$$V_{in}(t) = V_m \sin\left(\frac{2\pi t}{T_i}\right) \quad (1)$$

Internal series resistances of passive components are not taken into account for convenience in calculations. Both the boost and buck-boost operations of the converter provide the same inductor current ripple, which can be expressed as

$$\Delta i_L = \frac{V_{in}(t)DT_s}{L} \quad (2)$$

# International Journal of Advanced Research in Electrical, Electronics and Instrumentation Engineering

(An ISO 3297: 2007 Certified Organization)

Vol. 3, Issue 10, October 2014

The maximum current ripple corresponds to the peak input voltage. According to previous analyses, the inductor, diode, and MOSFETs share the same value of current ripple, which is designed in the following equation

$$\Delta i_L = \frac{V_m DT}{L} \quad (3)$$

From (3), the current ratings of all those components could be found. Thus the value of inductor can be designed as follows: Let us assume maximum current flows through inductor,  $i_{pk}=10A$ ,  $V_{in}=10V$ ,  $V_{out}=30V$ ,  $R=100\Omega$ ,  $f_s=50kHz$ .

$$\frac{V_o - V_{in}}{L} = d_2 T_2 \quad (4)$$

Condition for having discontinuous conduction is

$$d_2 < 1 - d_{1,max} \quad (5)$$

Let us assume  $d_{1,max}=0.8$  and then  $d_2 < 0.2$  for designing for discontinuous conduction. From (4) we have

$$d_2 = \frac{i_{pk} * L}{T_s (V_o - V_m)} < 0.2 \quad (6)$$

$$L < \frac{0.2 T_s (V_o - V_m)}{i_{pk}} \quad (7)$$

$f_s$  - Switching frequency

$T_s$  - Switching cycle

The voltage ratings of the MOSFETs and diodes are normally chosen higher than  $V_o$  with an appropriate margin for safe operation. The turn-on resistances of MOSFETs and the forward voltage drop of diodes are the major components, which impact the efficiency. The output filter capacitance should be selected in order to reduce the ripples presented in the output voltage. The value of capacitance is calculated from the graph.

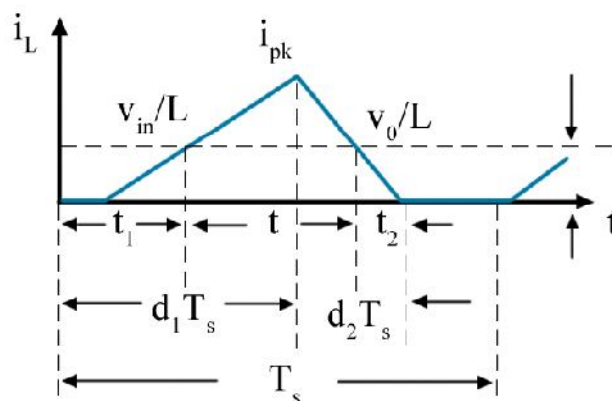

Figure 6: Waveform of inductor current

Both the boost and buck-boost operations of the converter From Fig. 3,

$$t = (d_1 + d_2) T_s - (t_1 + t_2) \quad (8)$$

The value of bus capacitance can be calculated from the relation:

# International Journal of Advanced Research in Electrical, Electronics and Instrumentation Engineering

(An ISO 3297: 2007 Certified Organization)

Vol. 3, Issue 10, October 2014

$$C = \frac{dQ}{dV} = \frac{0.5 * I_{Lpk} * t}{dV} \quad (9)$$

$I_{Lpk}$ - Peak inductor current

$\Delta V$  -Ripple voltage (0-10% of output voltage)

R - Load resistance

C – Capacitance

## IV. SIMULARION RESULTS

Simulation circuit for a bridgeless boost rectifier with input voltage 10V and output voltage of 30V is shown in Fig.7. The circuit components are selected in according to the relation (1)-(9) and are listed in the table 1.

**Table 1.** Margin specifications

Input voltage	10V
Output voltage	30V
Resistor	100 $\Omega$
Inductance	4.7*10 <sup>-6</sup> H
Capacitance	500*10 <sup>-6</sup> F
Switching frequency	50kHz
Duty cycle	0.78

Closed-loop voltage control successfully stabilizes the duty cycle at 0.78 at the steady state.

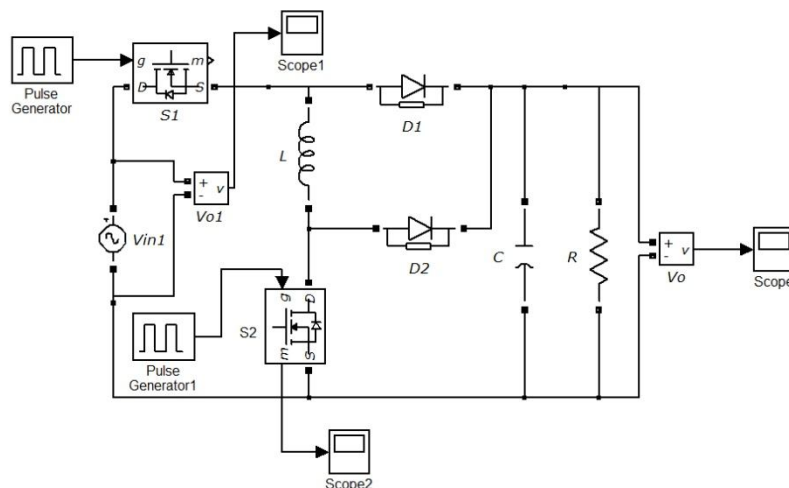

**Figure 7:** Simulation model of bridgeless boost rectifier

The bridgeless boost rectifier was simulated using MATLAB/SIMULINK and the resulting waveforms are as shown below.

# International Journal of Advanced Research in Electrical, Electronics and Instrumentation Engineering

(An ISO 3297: 2007 Certified Organization)

Vol. 3, Issue 10, October 2014

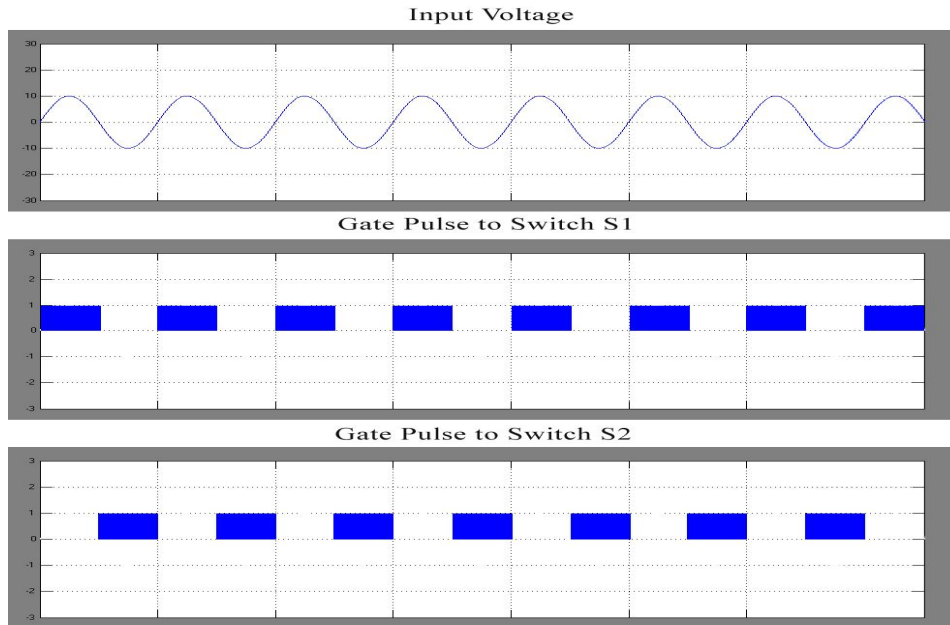

**Figure 8:** Input voltage and the waveforms of gate pulse generated for switch s1 and s2

During the positive input cycle,  $S_1$  is turned ON, while  $S_2$  is driven by the boost control scheme. When the circuit operates in the negative input cycle,  $S_2$  is turned ON, while  $S_1$  is controlled under the buck-boost conditioning strategy. As seen from Fig. 9, the output voltage is regulated at 30-V dc with approximately 0.2 V (i.e., 6%) voltage ripple.

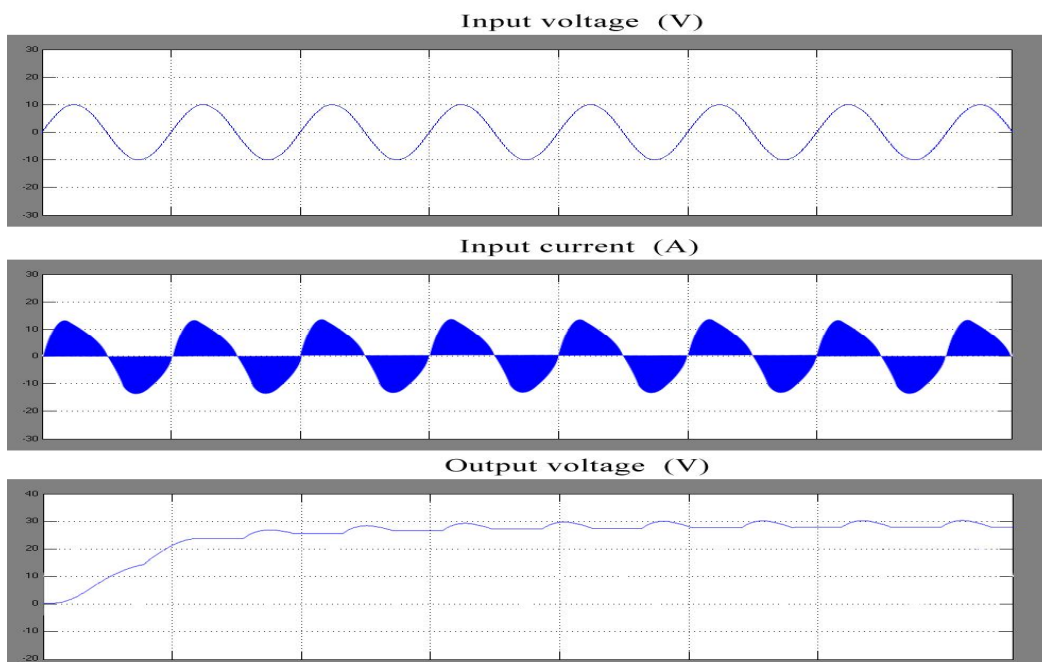

**Figure 9:** Input current and voltage waveform and output Voltage waveform of bridgeless boost rectifier



# International Journal of Advanced Research in Electrical, Electronics and Instrumentation Engineering

(An ISO 3297: 2007 Certified Organization)

Vol. 3, Issue 10, October 2014

## V.CONCLUSION

The bridgeless boost rectifier was simulated using MATLAB/SIMULINK. The topology combines a boost converter and a buck-boost converter to condition the positive input cycles, respectively. Only one inductor and one filter capacitor are required in this topology. The topology successfully boosts the 10V, 50Hz ac to 30Vdc. The output voltage regulated to 30V through closed loop voltage control. In comparison to state-of-art bridgeless rectifiers, this study employs the minimum number of passive energy storage components, and achieves the maximum conversion efficiency. Te future research will be focused on investigating and designing for much more voltage for various other applications and the distortion in the input current can be reduced by designing a suitable circuit.

## REFERENCES

- [1] Y. Rao and D. P. Arnold, Dec.2011 "An input-powered vibrational energy harvesting interface circuit with zero standby power," IEEE Trans.Power Electron. Vol. 26, no. 12, pp. 3524–3533.
- [2] S. Roundy, P. K. Wright, and J. Rabaey, July.2003 "A study of low level vibrations as a power source for wireless sensor nodes," Compute.Common, vol. 26, no. 11, pp. 1131–1144.
- [3] SumanDwari, Rohan Dayal, and Leila Parsa "A Novel direct AC/DC converter for efficient low voltage energy harvesting," IEEE Trans. Power Electron., vol. 27, no. 2, pp. 484–488.
- [4] SumanDwari and Leila Parsa,"Efficient Low Voltage Direct AC/DC Converters for Self-powered Wireless Sensor Nodes and Mobile Electronics" IEEE Trans.
- [5] M. R. Sahid, A. H. M. Yatim, Taufik Taufik,2010," A New AC-DC Converter Using Bridgeless SEPIC",IEEE,pp.286-290.[21] C.B.Williams, C. Shearwood, M. A. Harradine, P. H.Mellor, T. S. Birch, and R. B. Yates,Jun.2001 "Development of an electromagnetic micro-generator," IEE Proc. Circuits Devices Syst., vol. 148, no. 6, pp. 337–342.
- [6] S. Cheng, Y. Jin, Y. Rao, and D. P. Arnold, "An active voltage doubling AC/DC converter for low-voltage energy harvesting applications," *IEEE Trans. PowerElectron.*, vol. 26, no. 8, pp. 2258–2265, Aug. 2011.
- [7] Anoop D Nath, K. Radhakrishnan, Eldhose. K. A, "Low –voltage direct ac-dc boost converter for micro generator based energy harvesting," International Journal of Advanced Research in Electrical , Electronics and Instrumentation Engineering, vol. 2 issue.3,pp. 1045-1052, Mar.2013.
- [8] C. Peters, J. Handwerker, D. Maurath, and Y. Manoli, "A sub-500 mV highly efficient active rectifier for energy harvesting applications," *IEEE Trans. Circuits Syst. I: Reg*
- [9] E. Lefeuvre, D. Audigier, C. Richard, and D. Guyomar,"Buck-boost converter for sensor less poweroptimization of piezoelectric energy harvester," *IEEE Trans. Power Electron.*, vol. 22, no. 5, pp. 2018–2025, Sep. 2007.
- [10] S. Cheng, R. Sathe, R. D. Natarajan, and D. P. Arnold,"A voltage multiplying self-powered AC/DC converterwith 0.35-V minimum input voltage for energyharvesting applications," *IEEE Trans. Power Electron.*,vol. 26, no. 9, pp. 2542–2549, Sep. 2011.
- [11] Y.-P. Hsieh, J.-F. Chen, T.-J. Liang, and L. S. Yang, "Anovel high step-up dc–dc converter for a micro gridsystem," IEEE Trans. Power Electron., vol. 26, no. 4,pp. 1127–1136, Apr. 2011.
- [12] S. Park, Y. Park, S. Choi, W. Choi, and K.-B. Lee, "Soft-switched interleaved boost converters for highstep-up and high power applications," IEEE Trans.Power Electron., vol. 26, no. 10, pp. 2906–2914, Oct.2011.
- [13] Haoyu Wang, Yichao Tang, Alirezakhaligh, "Abridgeless boost rectifier for low voltage boost rectifierfor low voltage energy harvesting applications," *IEEETrans. on Power Electron.*, vol. 28, no. 11, pp. 5206-5214,Nov 2013.
- [14] B. Yuan, X. Yang, D. Li, Y. Pei, J. Duan, and J. Zhai,"A current-fed multi resonant converter with lowcirculating energy and zero-current switching for high step-up power conversion," IEEE Trans. Power Electron., vol. 26, no. 6, pp. 1613–1619, Jun. 2011.
- [15] S. Dwari and L. Parsa, "An efficient high-stepinterleaveddc–dc converter with a common active clamp," IEEE Trans.Power Electron., vol. 26, no. 1, pp. 66–78, Jan. 2011.
- [16] G. Spiazzi, P. Mattavelli, and A. Costabeber, "High step-up ratio fly back converter with active clamp andvoltage multiplier," IEEE Trans. Power Electron., vol. 26, no. 11, pp. 3205–3214, Nov. 2011.

## BIOGRAPHY



**Md. JahidHasanis** undergraduate student in department of Electrical and Electronic Engineering at American International University Bangladesh (AIUB). His main research interests include power electronic converters, Renewable Energy and Technology and Organic Circuitry.



**Md. Hasibul Islam**, Under graduated from American International University Bangladesh (AIUB), under the department of Electrical and Electronic Engineering. He has a good understanding on Power System Protection and Renewable Energy Technology.



**QaziTareqis** currently an undergraduate student in department of Electrical and Electronic Engineering at American International University Bangladesh (AIUB) and also volunteers as a research assistant with the Department of Electrical Engineering. His research interests are in power electronics, optoelectronics, renewable energy and nanotechnology.