



# **WDM-PON Architecture Implement Using AWG with Multicasting Efficiency**

**Nerkar Narendra N, Kadu Mahesh B**

Electronics and Telecommunication Department, AVCOE Sangamner, India.

**ABSTRACT:** We present the experimental demonstration of cascaded arrayed waveguide grating (AWG). Here we use the OLT (Optical Layer Termination) has 2 layer stacks. A tuneable one for unicast transmission and another one for multicast transmission. Downstream and upstream data share same optical path. BER curves were measured by using 2.5 GB per sec. data stream in each direction and error free transmission is achieved for downstream and upstream. For this proposed experimental setup is evaluated by using optic system software ver.12.

**KEYWORDS:** AWG, OLT ONU, WDM PON, TDM PON

## **I. INTRODUCTION**

The passive optical network (PON) is a promising solution to satisfy the ever-increasing bandwidth demand from enterprises or households. Considering the exponential growth of Internet traffic and emerging new applications such as high definition TV (HDTV), interactive games and video conference, etc., there is a need for much higher bandwidth. The wavelength-division multiplexing (WDM)-passive optical network (PON) has recently been considered to be an original technology which can satisfy these bandwidth requirements and overcome several limitations of existing PONs, which employ a splitter at a remote node (RN) [1-3].

In WDM-PON, the passive star coupler in a RN is replaced by a special passive optical device, called arrayed-waveguide gratings (AWGs). Each ONU is usually assigned a separate wavelength or channel, at least for downstream traffic, and these channels are routed by an AWG, sometimes more than one, located at a RN, whose routing characteristics depend on the wavelength. WDM-PON does not have multicast capability because it is a point-to-point (P2P) network for the downstream direction, from OLT to ONUs. However, the multicast transmission capability has become a very important requirement for access networks. In essence, it is required to provide the Triple Play Service (Data + voice + video), which is considered to be a promising business model or application. Therefore, the AWG-based WDM-PON should provide multicast transmission to satisfy the new requirements, and efficiently accommodate the TPS.

To provide multicast transmission in AWG-based WDM-PON, the following requirements are considered, in addition to cost. Firstly, an SCB should be possible. Unlike existing PON with a single wavelength and splitter at RN, the WDM-PON has problems providing an SCB, due to the nature of WDM. The multicast packet must be copied, to be the same wavelength, by a splitter in OLT. This results in many complicated problems, such as greater buffer size, processing overhead, signal attenuation, etc. Secondly, transparency of transmission is guaranteed for each multicast group. In AWG-based WDM-PON, several ONU's may receive the multicast data through the same wavelength, even though they are not subscribers of that service, because the wavelength can be reused at each input port of AWG. The multicast data of each service must be controlled independently, and prevented from being accepted by other multicast group ONUs using the same wavelength. Thirdly, the multicast traffic must be transmitted more flexibly, on a separated wavelength. Some architecture has been proposed for providing multicast transmission.

We propose a passive optical network (PON) architecture that uses wavelength multiplexing (WDM) for routing and time multiplexing (TDM) for laser sharing [4, 5]. At the same time, multicast and unicast traffic are wavelength multiplexed using the free spectral range (FSR) periodicity of the Arrayed Waveguide Gratings (AWGs) that are used to connect the Exchange Centre (Optical Layer Termination - OLT) with the user equipment (Optical Network Unit - ONU) [6, 7]. Two AWG stages are used to share equipment more efficiently [8]. The cost of the ONU is also critical because of the large number of them that are required and the fact that are a dedicated device for each end user. Therefore, a design based on simplicity and WDM transparency is presented, using a reflective modulator. The main novelties of this topology are the use of the FSR to transmit multicast data on the tuneable laser stack located at the

# International Journal of Advanced Research in Electrical, Electronics and Instrumentation Engineering

(An ISO 3297: 2007 Certified Organization)

Vol. 5, Issue 6, July 2016

OLT to send unicast data to the ONUs on TDM basis. Also, the utilization of the proposed routing technique using two cascaded AWGs to share multicast transmitters is innovative.

## II. PROPOSED HYBRID WDM/TDM PON ARCHITECTURE

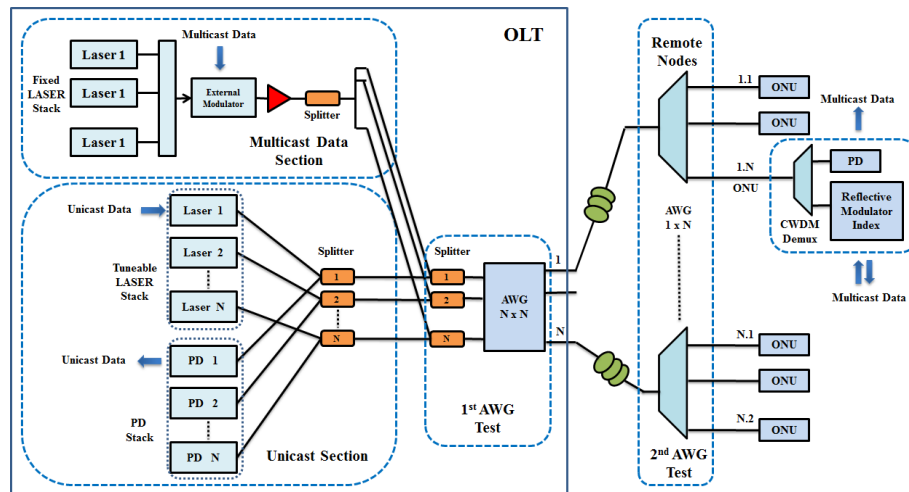

**Figure1:** A hybrid WDM/TDM PON architecture with two cascaded AWG.

The network architecture is presented in Figure 1. It is based on two cascaded AWGs. The first stage is an  $N \times N$  AWG that interconnects the optical transmission equipment with  $N$  remote nodes. These remote nodes are  $1 \times N$  AWGs that route  $2 \cdot N$  wavelengths to each of the output ports, using the main pass band and the adjacent AWG FSR. The ONU has two receivers. The multicast receiver is a simple photo detector. The unicast receiver needs to also be able to modulate upstream data. Any device that can remotely modulate the carrier sent from the OLT is suitable to be used, like a Reflective Semiconductor Amplifier (RSOA) [8]. As there is no light generation at the ONU, these are wavelength independent. However, an unmodulated optical carrier needs to be sent from the OLT. The OLT optical sources are a tuneable laser stack and a fixed laser stack. The tuneable laser stack performs unicast transmission and is shared on TDM basis among  $N$  ONUs, which is connected to one of the  $N$  remote nodes. This architecture allows dynamic bandwidth allocation as time slots can be dynamically assigned depending on the transmission. The OLT optical sources are a tuneable laser stack and a fixed laser stack. The tuneable laser stack performs unicast transmission and is shared on TDM basis among  $N$  ONUs, which is connected to one of the  $N$  remote nodes. The fixed laser stack is composed of  $N$  fixed lasers with wavelengths compatible with the AWG routing table, not using the main pass band but the adjacent FSR. The optical sources are coupled and modulated with a single modulator and then split to the  $N$  input ports of the  $N \times N$  central AWG. Optical Amplification after the modulator is required. This architecture shares each laser by a factor of  $N$ . Each tuneable laser serves  $N$  users on TDM basis while the  $N$  lasers from the multicast laser stack serve the entire network, to which  $N \times N$  users can be connected.

**Table 1:** The different parameters that are utilized for the simulation.

Parameter	SMF
Dispersion	16 ps/nm/km
Dispersion slope	-0.08ps/nm <sup>2</sup> /km
PMD coefficient	0.2 ps/km
Effective Area	80 $\mu\text{m}^2$
Nonlinearity Coefficient	$2.6 \times 10^{-20}$
Attenuation	0.2 dB/Km

### III. EXPERIMENTAL SET UP

The proposed experimental set up is shown in Figure .2. As shown in OLT ,we have used fixed laser stack to generate a light of different wavelength .In fixed laser stack, we have used 8 laser which generate a light of wavelength of 1544.4 nm ,1545.2,1546 nm ,1546.8 nm,1547.6 nm, 1548.4 nm,1549.2 nm and 1550 nm with channel spacing equal to 0.8 nm. These light signals of difference wavelength are modulated with data which is multicast data of 2.5Gbps with the help of eternal modulator. These modulated signals are amplified with the help of amplifier and applied to splitter (1:8) which will splits a incoming signals .The output signals of splitter are applied as input for AWG (8\*8)IN OLT. Here, AWG's role is to multiplex the signals which are carrying multicast data from OLT .This multiplexed multicast data signals are transmitted to ONU through 30 km length single mode fibre (SMF) which provide attenuation of 0.25dB/km. The multicast data signals are DE multiplexed with the help of AWG (8\*8) in RN. At RN, AWG DE multiplex the incoming signals and are proceed to ONU .At ONU, these signal are accepted by PIN photodiode optical receiver .This PIN photodiode is having responsively equal to 0.7 A/W, dark current equal to 10 Na. At optical receiver thermal noise, ASE noise and shot noise are taken into consideration. After optical to electrical conversation, the performance analysis for transmission of multicast data is done with the help of eye diagram, and BER. At ONU, separate optical sources are used for the transmission of unicast data. 8 Optical sources are used which are having extinction ratio equal to 20 dB and line width equal to 10MHZ.

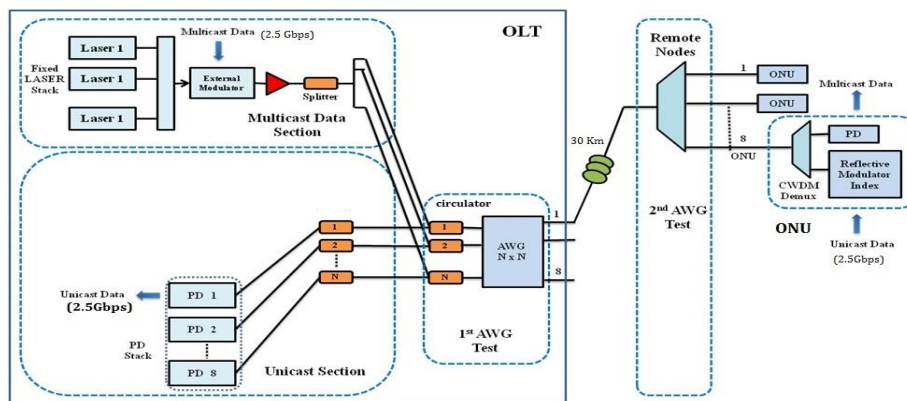

**Figure 2:** Proposed Experimental Set up.

Unicast data is equal to 2.5 Gbps. 8 optical sources generate a light of difference wavelength from 1544.4 nm to 1550 nm with channel spacing equal to 0.8 nm. These light carriers are modulated with the help of unicast data 2.5 Gbps .These signals are multiplexed with the help of AWG which is present in RN. This multiplexed signal is transmitted via 30 km bidirectional SMF. At OLT, AWG demultiplex the incoming signals and are proceed to receiver. At OLT, these signals are accepted by PIN photodiode optical receiver. This PIN photodiode is having responsivity equal to 0.7 A/W, dark current equal to 10 Na. At optical receiver thermal noise, ASE noise and shot noise are taken into consideration. After optical to electrical conversation, the performance analysis for transmission of multicast data is done with the help of eye diagram, and BER.

### IV. SIMULATION RESULTS AND DICUSSION

**Table 2:** Performance analysis of Multicast data transmission.

I/P Optical power (dBm)	Received Optical Power (dBm)								BER							
	1544.4 nm	1545.2 nm	1546 nm	1546.8 nm	1547.6 nm	1548.4 nm	1549.2 nm	1550 nm	1544.4 nm	1545.2 nm	1546 nm	1546.8 nm	1547.6 nm	1548.4 nm	1549.2 nm	1550 nm
0	-14.19	-14.18	-14.1	-14.19	-14.1	-14.1	-14.18	-14.1	0	0	0	0	0	0	0	0
-2	-16.05	16.055	-16.0	16.053	-16.0	-16.04	16.053	16.03	2.48E-252	3.85E-192	3.15E-231	2.62E-214	2.20E-206	2.11E-198	7.20E-182	5.90E-169
-3	-17.19	17.193	17.189	17.193	17.182	17.185	17.189	17.17	9.04E-132	5.17E-145	1.28E-138	6.57E-140	2.10E-137	3.11E-137	2.44E-124	9.50E-111
-4	-18.18	18.191	-18.1	-18.19	18.182	18.187	18.187	18.18	5.34E-93	2.49E-89	7.96E-94	3.49E-91	6.40E-94	2.94E-88	5.91E-82	3.38E-72
-5	-19.18	-19.19	-19.1	-19.19	19.182	19.187	19.187	19.17	1.60E-60	3.61E-58	8.21E-61	2.09E-59	3.93E-61	1.06E-57	1.86E-54	3.10E-47

**Table 3:** Performance analysis of Unicast data transmission.

Received Optical Power (dBm)									BER							
I/P Optical power (dBm)	1544.4 nm	1545.2 nm	1546 nm	1546.8 nm	1547.6 nm	1548.4 nm	1549.2 nm	1550 nm	1544.4 nm	1545.2 nm	1546 nm	1546.8 nm	1547.6 nm	1548.4 nm	1549.2 nm	1550 nm
0	-19.10	-19.06	-19.04	-19.1	-19.03	-19	-19.05	-19.2	3.55E-123	4.04E-76	1.04E-70	1.78E-78	4.12E-55	2.15E-75	1.94E-101	1.16E-108
-2	-21.10	-21.05	-21.051	-21.03	-21.03	-21.04	-21.05	-21.1	2.53E-52	2.78E-34	8.51E-32	1.46E-33	7.47E-25	2.73E-35	6.69E-46	1.03E-45
-3	-22.11	-22.06	-22.05	-22.04	-22.05	-22.05	-22.05	-22.1	1.28E-35	4.42E-23	1.89E-21	3.07E-22	1.30E-16	2.53E-23	7.90E-30	8.05E-31
-4	-23.11	-23.06	-23.04	-23.04	-23.04	-23.04	-23.04	23.13	1.95E-22	8.91E-15	4.34E-14	1.21E-14	2.33E-11	1.25E-15	2.04E-20	5.81E-20
-5	-24.1	-24.1	-24.04	-24.04	-24.1	-24.04	-24.2	24.13	2.67E-15	4.14E-10	1.73E-09	5.42E-10	7.48E-08	2.11E-10	2.19E-13	2.17E-15

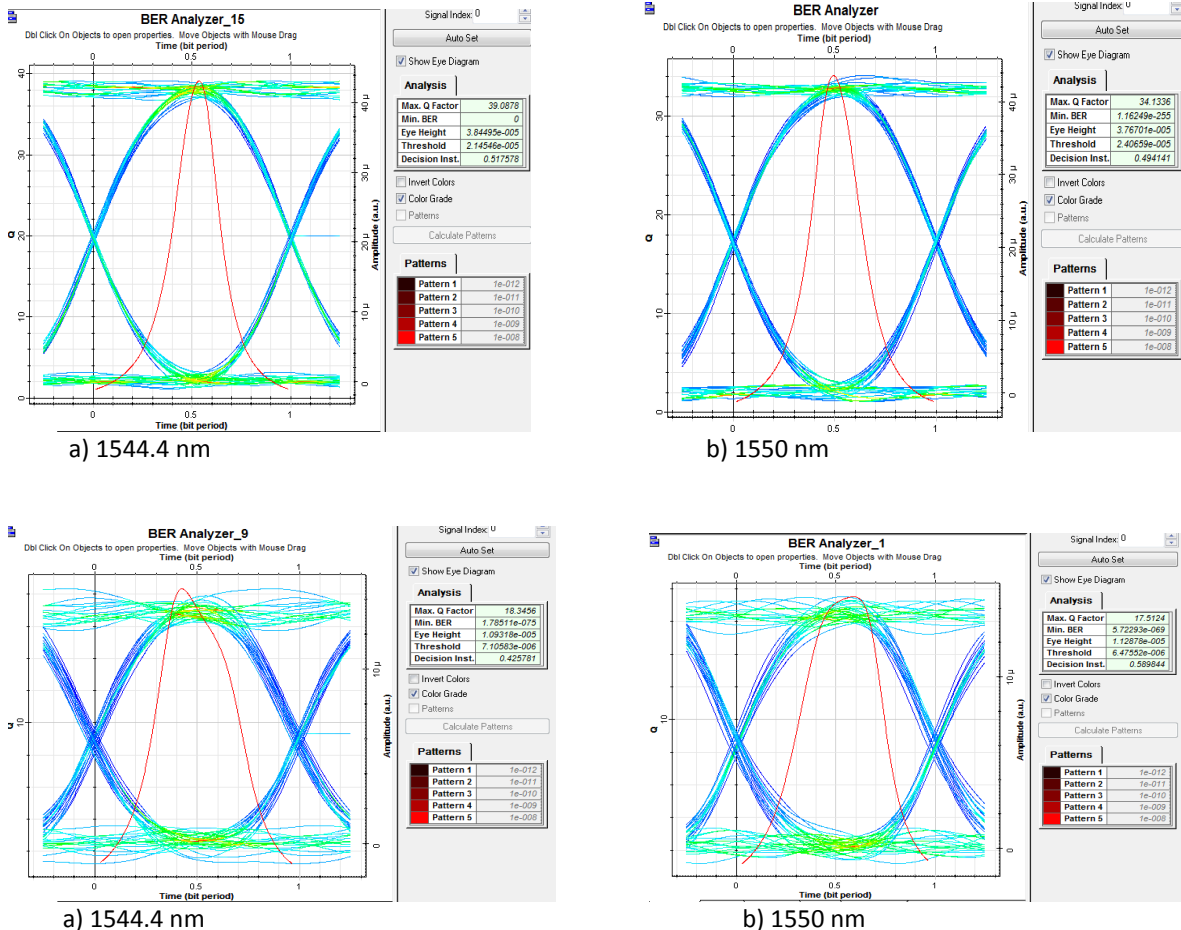

**Figure 3, 4:** Eye diagram for Unicast data transmission for wavelength 1544.4 nm and 1550 nm.

Both unicast and multicast data was modulated at 2.5Gbps with PRBS 223-1, using two external LiNbO3 modulators. Sequences were de-correlated using an electrical delay line. Both lasers offered nominal output power of 0dBm. 30Km of SMF connected the central AWG to the remote node and an optical attenuator was used after the remote node to obtain BER against Pin curves. The ONU receiver was composed by an PIN photo detector. An optical Coarse WDM (C-WDM) de-multiplexer was also used to recover unicast and multicast data independently. Results for unicast and multicast reception at the ONU are depicted in Table 1 and Table 2. These results are obtained by varying input optical



ISSN (Print) : 2320 – 3765  
ISSN (Online): 2278 – 8875

# International Journal of Advanced Research in Electrical, Electronics and Instrumentation Engineering

(An ISO 3297: 2007 Certified Organization)

**Vol. 5, Issue 6, July 2016**

power from -5 to 0 dBm .The results are mentioned in terms of received optical power vs. BER for corresponding wavelength. As shown in Figure.3 eye diagrams are obtained for multicast data after 30 km transmission for wavelength 1544.4 nm and 1550 nm respectively. As shown in Figure.4 eye diagrams are obtained for unicast data after 30 km transmission for wavelength 1544.4 nm and 1550 nm respectively.

## V. CONCLUSION

In the proposed architecture, we studied the performance of WDM-PON. Novel network architecture to transmit Multicast and unicast data using the inherent free spectral range (FSR) periodicity of two cascaded AWGs is presented. A shared tuneable laser stack provides unicast transmission capabilities while a fixed laser stack is used for multicast transmission. Optical tests at 2.5Gbps over 30km of SMF confirm the feasibility of the proposed network platform.

## REFERENCES

1. RD Feldman, An Evaluation of Architectures Incorporating Wavelength Division Multiplexing for Broad-Band Fiber Access, J Lightwave Tech 1998; 16: 1546-1559.
2. K Han, W Yang, et al. An AWG-based WDM-PON Architecture employing WDM/TDMA Transmission for Upstream Traffic with Dynamic Bandwidth Allocation, Photonic Network Communications 2008; 15: 191-202.
3. G Mario, Design and Cost Performance of the Multistage WDM-PON Access Networks, IEEE/OSA J. Light wave Technology Feb 2000;18: 125-143.
4. C Bock et al, Scalable Two-stage Multi-FSR WDM-PON Access Network Offering Centralized Dynamic Bandwidth Allocation, in Proceedings of European Conference on Optical Communications (Stockholm, Sweden, 2004), Tu4.6.6.
5. FT An et al, SUCCESS: a next-generation hybrid WDM/TDM optical access network architecture, IEEE/OSA JLT 11, 2557-2569 (2004).
6. SD Walker et al, Arrayed-waveguide grating based WDM access networks: an evolutionary multi-Gb/s upgrade path, in Proceedings of ISSLS (Stockholm, Sweden, 2000).
7. A Martinez et al, High Speed Switched Multiservice AWG-PON using CWDM and Spectral Periodicity of Arrayed Waveguide Gratings, in Proceedings of European Conference on Optical Communications (Rimini, Italy, 2003), Th2.4.4.
8. I Tsalamanis et al, Experimental demonstration of cascaded AWG access network featuring bi-directional transmission and polarization multiplexing, Opt. Express 2004; 12: 764-769.